

CORRENTI &
MOVIMENTI



Aldo Bernardi®

CORRENTI & MOVIMENTI



Aldo Bernardi®



Aldo Bernardi presenta in questo catalogo una serie di accessori che permettono di realizzare un impianto elettrico su superficie. Trattasi di interruttori, raccordi, scatole di derivazione, tubi dentro ai quali far passare il cavo elettrico, da abbinare alle lampade ed applique di nostra produzione. Tutti i sistemi presentati, da quello classico Civetta a quelli di “ultima generazione” quali i sistemi MODULARI, **permettono di raggiungere qualsiasi punto della parete** alla quale vengono fissati e, soprattutto **vengono realizzati su specifica, in base alle esigenze del cliente.** Accanto alla classica finitura in ottone anticato sono presenti nuove finiture che ne valorizzano la manifattura: l’elegante finitura nichel o nichel satinato, adatte anche ad ambienti non necessariamente classici, la nuova finitura cromo e l’esclusiva finitura Rustic Silver[®], che rende questi oggetti unici e di pregio, con un valore aggiunto dato dall’utilizzo di uno strato di argento puro depositato sulla superficie e successivamente anticato.

In this catalogue Aldo Bernardi presents a series of accessories that make surface mounted wiring system possible. These are switches, connectors, junction boxes, pipes through which the electric wires are passed that can be combined with appliances of our production. All the systems shown, from the classic Civetta to those of “next generation” as MODULAR systems, **can reach any point of the wall** on which are fixed and, above all, **are realized on specific, according to customer needs.** Besides the antique brass finish there are news finishes that enhance the craftsmanship: the fine satin nickel or nickel finish suitable for environments not necessarily classic, the new chrome finishes and the exclusive Rustic Silver[®] finish, that makes these items unique, with a surplus value given by the use of a pure silver layer, deposited on the surface and subsequently aged.

Impianto a vista / Surface wiring system

page 7



scatole di derivazione
junction boxes
page 16



prese e interruttori
sockets and switches
page 18



raccordi e supporti
connections and accessories
page 28

Civetta

page 37



sistema "Multi-Ap"
page 40



sistema SPR
nome
page 46

Impianto modulare / Modular system

page 53



sistema i Quadri
page 54



sistema i Rombi
page 60



sistema Grafico
page 68



sistema Ibrido
page 82

Impianto a treccia / Braid system

page 87



linea Castore
page 94



linea Polluce
page 98



linea Antares
page 100



linea Sirio
page 102



linea Rigel
page 104



linea Bellatrix
page 106



linea Meissa
page 108



linea Schengen
page 111



linea Acquario
page 112



linea Mimosa
page 120



linea Pleiadi
page 122



IMPIANTO A VISTA SURFACE WIRING SYSTEM

Qualsiasi parete, soprattutto quelle a sasso vivo, non possono che venire valorizzate dalle componenti che Aldo Bernardi, da anni propone con successo, per la realizzazione di un impianto “a vista”.

Any wall, especially those on stone, are enhanced by the components that Aldo Bernardi, for many years successfully proposes, for the realization of a surface wiring system.



A Chicago, in Merchandise Mart, si trova l'interessante Charles Pollock Showroom. Aldo Bernardi ha illuminato parte dello show room. L'impianto su canaletta, le sospensioni e le applique Aldo Bernardi trovano in questo interessante spazio l'ambiente ideale dove esprimere nel modo migliore tutte le proprie potenzialità.

Located on the 18th floor of the world famous Chicago's Merchandise Mart is the Charles Pollock Showroom. The surface mounted conduit system, Aldo Bernardi pendants and wall lamps find in this interesting space the background where better express all its potentials.

Immersa nel verde, tra Milano ed i laghi di Como e Maggiore, si trova questa bella azienda, una tranquilla oasi con alberi da frutto, piante e fiori. Per l'illuminazione degli spazi esterni sono stati collocati apparecchi per illuminazione Aldo Bernardi. Le applique sono utilizzate sia nella versione a parete sia nella versione testa palo per l'illuminazione di vialetti e giardini.

This is a natural retreat in the heart of the Brianza district, surrounded by the countryside between Milan and Lakes Como and Maggiore, a peaceful oasis with fruit trees, plants and flowers. For the external lighting Aldo Bernardi collection has been used, with wall lights and lighting poles to illuminate paths and gardens.





Nel "Teatro Art Studio" di Mosca, ricostruito sulle ceneri di quello che era il vecchio teatro "Stanislavsky", e rinnovato, l'illuminazione è stata realizzata con l'impianto "a vista" collegato agli apparecchi di illuminazione Aldo Bernardi.

In the "Theatre Art Studio" in Moscow, preserved and renovated over the ashes of the old "Stanislavsky" factory, lighting has been done with surface wiring system connected to Aldo Bernardi luminaires.











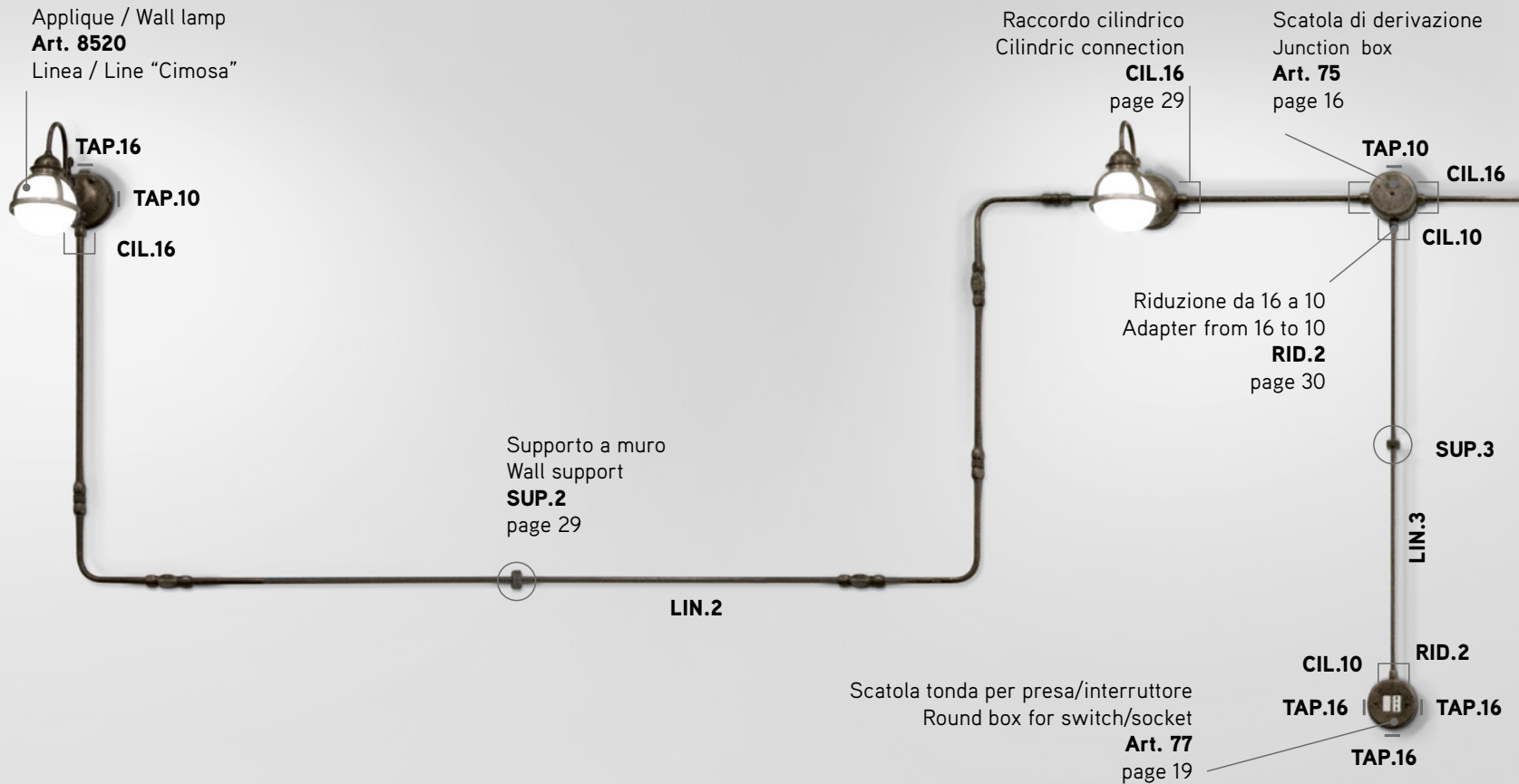

Per questa composizione sono stati utilizzati i seguenti accessori:

- N° 3 applique (**Art. 8520** linea Cimosa)
- N° 1 scatola di derivazione tonda a 4 uscite (**Art. 75**)
- N° 1 scatola tonda per prese/interruttori (**Art. 77**)
- N° 1 scatola di derivazione rettangolare a 6 uscite (**Art. 90**)
- N° 1 scatola rettangolare per prese/interruttori (**Art. 99**)
- N° 1 interruttore rotativo (**Art. 79**)
- N° 8 raccordi volanti per canaletta da \varnothing 16 mm (**Art. VOL.2**)
- N° 1 raccordi volanti per canaletta da \varnothing 10 mm (**Art. VOL.3**)
- N° 8 raccordi a muro per canaletta da \varnothing 16 mm (**Art. RAC.2**)
- N° 1 raccordi a muro per canaletta da \varnothing 10 mm (**Art. RAC.3**)
- N° 4 supporto a muro per canaletta da \varnothing 16 mm (**Art. SUP.2**)
- N° 2 supporto a muro per canaletta da \varnothing 10 mm (**Art. SUP.3**)
- N° 4 raccordi cilindrici per uscita da \varnothing 10 mm (**Art. CIL.10**)
- N° 8 raccordi cilindrici per uscita da \varnothing 16 mm (**Art. CIL.16**)
- N° 4 raccordi cilindrici per uscita da \varnothing 20 mm (**Art. CIL.20**)
- N° 3 riduzione da \varnothing 20 a 16 mm (**Art. RID.1**)
- N° 4 riduzione da \varnothing 16 a 10 mm (**Art. RID.2**)
- N° 5 tappi di chiusura per uscite da \varnothing 20 mm (**Art. TAP.20**)
- N° 2 tappi di chiusura per uscite da 16 mm (**Art. TAP.16**)
- N° 1 tappi di chiusura per uscite da 10 mm (**Art. TAP.10**)
- N° 8 tubo curvo da \varnothing 16 mm (**Art. CUR.2**)
- N° 1 tubo curvo da \varnothing 10 mm (**Art. CUR.3**)
- N° 1 tubo lineare da \varnothing 20 mm (**Art. LIN.1**)
- N° 5 tubo lineare da \varnothing 16 mm (**Art. LIN.2**)
- N° 1 tubo lineare da \varnothing 10 mm (**Art. LIN.3**)

I tappi in ottone tornito e anticato per chiudere le uscite da \varnothing 20, 16 e 10 mm sono già inclusi nei rosoni e nelle basi per applique. Sono invece da ordinare a parte per chiudere le uscite non utilizzate delle scatole di derivazione, interruttori e prese.

To compose this solution has been utilized following articles:

- N° 3 wall lamp (**Art. 8520** Cimosa line)
- N° 1 round junction box with 4 exits (**Art. 75**)
- N° 1 round box for switches/sockets (**Art. 77**)
- N° 1 rectangular junction box with 6 exits (**Art. 90**)
- N° 1 rectangular box for switches/sockets (**Art. 99**)
- N° 1 rotary switch (**Art. 79**)
- N° 8 flying connection for tubes section \varnothing 16 mm (**Art. VOL.2**)
- N° 1 flying connection for tubes section \varnothing 10 mm (**Art. VOL.3**)
- N° 8 wall connection for tubes section \varnothing 16 mm (**Art. RAC.2**)
- N° 1 wall connection for tubes section \varnothing 10 mm (**Art. RAC.3**)
- N° 4 wall support for tubes section \varnothing 16 mm (**Art. SUP.2**)
- N° 2 wall support for tubes section \varnothing 10 mm (**Art. SUP.3**)
- N° 4 cylindric connection for output \varnothing 10 mm (**Art. CIL.10**)
- N° 8 cylindric connection for output \varnothing 16 mm (**Art. CIL.16**)
- N° 4 cylindric connection for output \varnothing 20 mm (**Art. CIL.20**)
- N° 3 adapter from \varnothing 20 to 16 mm (**Art. RID.1**)
- N° 4 adapter from \varnothing 16 to 10 mm (**Art. RID.2**)
- N° 5 caps for output \varnothing 20 mm (**Art. TAP.20**)
- N° 2 caps for outpu \varnothing 16 mm (**Art. TAP.16**)
- N° 1 caps for output \varnothing 10 mm (**Art. TAP.10**)
- N° 8 bent tube section \varnothing 16 mm (**Art. CUR.2**)
- N° 1 bent tube section \varnothing 10 mm (**Art. CUR.3**)
- N° 1 bent tube section \varnothing 20 mm (**Art. LIN.1**)
- N° 5 bent tube section \varnothing 16 mm (**Art. LIN.2**)
- N° 1 bent tube section \varnothing 10 mm (**Art. LIN.3**)

Caps in turned brass, subsequently aged used to cap off 20,16 and 10 mm \varnothing openings are included with wall pendant and sconces. They must be ordered separately to cap off unused openings in junction boxes, switches or sockets.

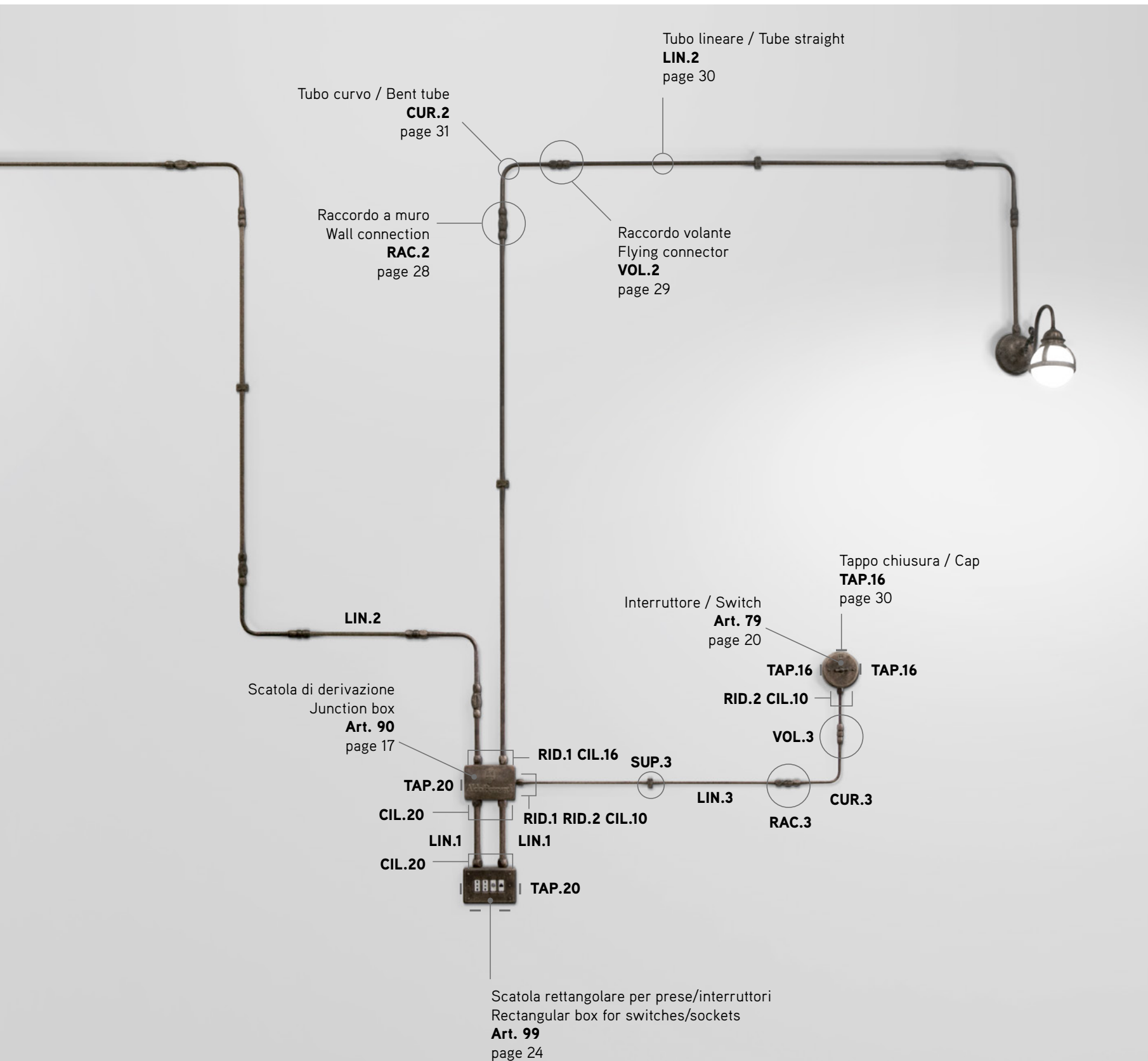

Scatole di derivazione

Junction boxes



Scatola di derivazione tonda Round junction box

Scatola di derivazione tonda in fusione di ottone, disponibile nelle finiture ottone anticato, nichel e Rustic Silver™, a quattro uscite, due con sezione da Ø 10 mm e due con sezione da Ø 16 mm. Sezioni uguali sono parallele tra loro ed orientabili a piacere. La scatola si fissa al muro con appositi tasselli.

L'articolo va integrato con componenti qui di seguito descritti e da ordinare a parte:

- art. **TAP.10** e art. **TAP.16** per chiudere le uscite non utilizzate
- art. **CIL.10** per utilizzare le uscite con sezione da Ø 10 mm
- art. **CIL.10**, integrato con l'articolo **RID.2** per utilizzare l'uscita con sezione da Ø 16 mm ridotta a sezione Ø 10 mm
- art. **CIL.16** per utilizzare l'uscita con sezione da Ø 16 mm

Round junction box in cast brass, available in aged brass, nickel and Rustic Silver™ finishes, with four outlets, two with 10 mm diam. section and two with 16 mm diam. section. Equal sections are parallel and adjustable. The box fixes to the wall with special plugs. This article can be completed with our components here described, to be ordered separately:

- art. **TAP.10** and art. **TAP.16** to close the unused outlets.
- art. **CIL.10** to use outlets with section 10 mm diam.
- art. **CIL.10**, completed with article **RID.2** to use the outlet with section 16 mm diam. reduced to section 10 mm diam.
- art. **CIL.16** to use outlets with section 16 mm diam.

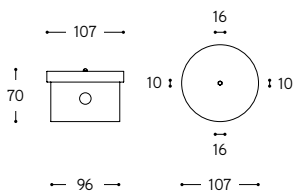

ARTICOLO ITEM	PESO GR. WEIGHT GR.	VOL. IN M ³ VOL. IN M ³	PEZZI IMBALLO OUTER BOX	FASCIA PREZZO PRICE RANGE
75 Ottone / Brass				B39
75.NI Nichel / Nickel	1.180	0,001	1	B39
75.RS Rustic Silver™				B47



Scatola di derivazione ovale Oval junction box

Scatola di derivazione ovale, in fusione di ottone, disponibile nelle finiture ottone anticato, nichel e Rustic Silver™, a quattro uscite, tutte con sezione da Ø 16 mm. La scatola si fissa al muro con appositi tasselli. L'articolo va integrato con componenti qui di seguito descritti e da ordinare a parte:

- art. **TAP.16** per chiudere le uscite non utilizzate
- art. **CIL.16** per utilizzare l'uscita con sezione da Ø 16 mm
- art. **CIL.10**, integrato con l'articolo **RID.2** per utilizzare l'uscita con sezione da Ø 16 mm ridotta a sezione Ø 10 mm

Oval junction box in cast brass, available in aged brass, nickel and Rustic Silver™ finishes, with four outlets, all with 16 mm diam. section. The box fixes to the wall with special plugs. Here described the components used for making up the box, to be ordered separately:

- art. **TAP.16** to close the unused outlets
- art. **CIL.16** to use outlets with section 16 mm diam.
- art. **CIL.10**, completed with article **RID.2** to use the outlet with section 16 mm diam. reduced to section 10 mm diam.

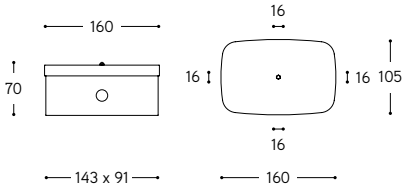

ARTICOLO ITEM	PESO GR. WEIGHT GR.	VOL. IN M ³ VOL. IN M ³	PEZZI IMBALLO OUTER BOX	FASCIA PREZZO PRICE RANGE
80 Ottone / Brass				B45
80.NI Nichel / Nickel	1.580	0,001	1	B45
80.RS Rustic Silver™				B58



Scatola di derivazione rettangolare Rectangular junction box

Scatola di derivazione rettangolare, in fusione di ottone, disponibile nelle finiture ottone anticato, nichel e Rustic Silver™, a sei uscite tutte con sezione da Ø 20 mm. La scatola si fissa al muro con appositi tasselli. L'articolo va integrato con componenti qui di seguito descritti e da ordinare a parte:

- art. **TAP.20** per chiudere le uscite non utilizzate
- art. **CIL.20** per utilizzare l'uscita da Ø 20 mm
- art. **CIL.16** integrato con l'articolo **RID.1** per utilizzare l'uscita con sezione da Ø 20 mm ridotta a sezione Ø 16 mm
- art. **CIL.10** integrato con gli articoli **RID.1** e **RID.2** per utilizzare l'uscita con sezione da Ø 20 mm ridotta a sezione Ø 10 mm

Rectangular junction box in cast brass, available in aged brass, nickel and Rustic Silver™ finishes, with six outlets, all with 20 mm diam. section. The box fixes to the wall with special plugs. Here described the components used for making up the box, to be ordered separately:

- art. **TAP.20** to close the unused outlets
- art. **CIL.20** to use the outlets with section 20 mm diam.
- art. **CIL.16** completed with article **RID.1** to use the outlet with section 20 mm diam. reduced to section 16 mm diam.
- art. **CIL.10**, completed with articles **RID.1** and **RID.2** to use the outlet with section 20 mm diam. reduced to section 10 mm diam.

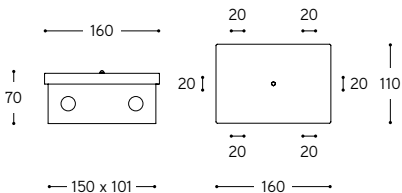

ARTICOLO ITEM	PESO GR. WEIGHT GR.	VOL. IN M ³ VOL. IN M ³	PEZZI IMBALLO OUTER BOX	FASCIA PREZZO PRICE RANGE
90 Ottone / Brass				B49
90.NI Nichel / Nickel	1.890	0,001	1	B49
90.RS Rustic Silver™				B62



Scatola di derivazione rettangolare Rectangular junction box

Scatola rettangolare in fusione di ottone, disponibile nelle finiture ottone anticato, nichel e Rustic Silver™, a dieci uscite laterali, tutte con sezione da Ø 20 mm. L'articolo va integrato con componenti qui di seguito descritti e da ordinare a parte:

- art. **TAP.20** per chiudere le uscite non utilizzate
- art. **CIL.20** per utilizzare le uscite da Ø 20 mm
- art. **CIL.16** integrato con art. **RID.1** per utilizzare le uscite da Ø 20 mm ridotte a sezione Ø 16 mm
- art. **CIL.10** integrato con gli articoli **RID.1** e **RID.2** per utilizzare le uscite da Ø 20 mm ridotte a sezione Ø 10 mm

La scatola può essere fornita in IP44. In questo caso la scatola è comprensiva di tappi di chiusura mentre gli altri eventuali raccordi vanno ordinati a parte.

Rectangular junction box in cast-brass available in aged brass, nickel and Rustic Silver™ finishes, with ten lateral 20 mm. diam. section outputs. Here described the components used for making up the box, to be ordered separately:

- art. **TAP.20** to close the unused outputs
- art. **CIL.20** for outputs with the 20 mm diam. section
- art. **CIL.16** with art. **RID.1** for outputs with the 20 mm diam. Section reduced to 16 mm diam.
- art. **CIL.10** with articles **RID.1** and **RID.2** for outputs with the 20 mm diam. section reduced to 10 mm diam.

The box can be provided in IP44. In this case the component TAP.20 is included while the others eventual componenets must be orered separately.

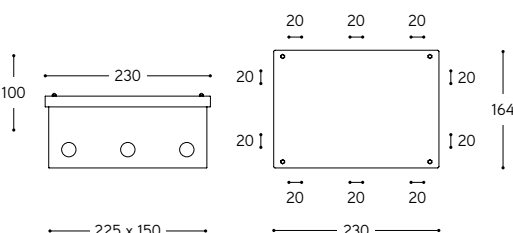

ARTICOLO ITEM	PESO GR. WEIGHT GR.	VOL. IN M ³ VOL. IN M ³	PEZZI IMBALLO OUTER BOX	FASCIA PREZZO PRICE RANGE
SD 100 Ottone / Brass				B67
SD 100.NI Nichel / Nickel	6.200	0,02	1	B67
SD 100.RS Rustic Silver™				B81
SD 100/IP44 Ottone + 10 TAP.20 / Brass + 10 TAP.20				B74
SD 100/IP44.NI Nichel + 10 TAP.20 / Nickel + 10 TAP.20	6.200	0,02	1	B74
SD 100/IP44.RS Rustic Silver™ + 10 TAP.20				B88

Prese e interruttori

Sockets and switches



Interruttore a parete Wall switch

Interruttore a parete, con base in ceramica, smaltata bianca e parte superiore in fusione di ottone, disponibile nelle finiture ottone anticato, nichel e Rustic Silver™. Sulla base in ceramica l'interruttore ha quattro uscite sulle quali è possibile inserire le canalette da Ø 16 mm per l'impianto elettrico dentro a canaletta.

Wall switch, with ceramic base, white enamelled and top part in cast brass, available in aged brass, nickel and Rustic Silver™ finishes. On the ceramic base the switch has four outlets for inserting 16 mm diam. raceways for the electrical system inside brass conduit.

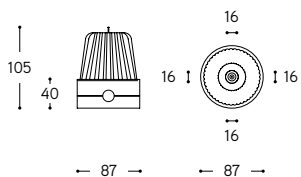

ARTICOLO ITEM	V	A	PESO GR. WEIGHT GR.	VOL. IN M ³ VOL. IN M ³	PEZZI IMBALLO OUTER BOX	FASCIA PREZZO PRICE RANGE
50/40 Ottone / Brass						B42
50/40.NI Nichel / Nickel	250	10	919	0,001	1	B42
50/40.RS Rustic Silver™						B51

Scatola rotonda Round box

Scatola rotonda per due prese e/o interruttori. La base è in fusione di ottone, disponibile nelle finiture ottone anticato, nichel e Rustic Silver™, a quattro uscite laterali, tutte con sezione da Ø 16 mm. La parte superiore della scatola è in gres ceramico. La scatola è predisposta per apparecchi della serie Vimar 8000 che non sono forniti con l'articolo. L'articolo va integrato con componenti qui di seguito descritti e da ordinare a parte:

- art. **TAP.16** per chiudere le uscite non utilizzate
- art. **CIL.16** per utilizzare le uscite da 16 mm Ø
- art. **CIL.10** integrato con l'articolo **RID.2** per utilizzare le uscite da Ø 16 mm ridotte a sezione Ø 10 mm

Round box with ceramic-gres cover and cast-brass base, available in aged brass, nickel and Rustic Silver™ finishes, with four lateral outputs 16 mm diam. section. The cover is arranged for two switches and/or plugs. The box is arranged for plugs/switches Vimar 8000 not here included. The article can be connected to all those accessories, here described, used for making up the box, to be ordered separately:

- art. **TAP.16** to close the unused outputs
- art. **CIL.16** for outputs with the 16 mm diam. section
- art. **CIL.10** with art. **RID.2** for outputs with the 16 mm diam. section reduced to 10 mm diam.

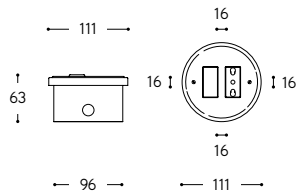

ARTICOLO ITEM	PESO GR. WEIGHT GR.	VOL. IN M ³ VOL. IN M ³	PEZZI IMBALLO OUTER BOX	FASCIA PREZZO PRICE RANGE
76 Ottone / Brass				B37
76.NI Nichel / Nickel	840	0,01	1	B37
76.RS Rustic Silver™				B44

Scatola rotonda Round box

Scatola rotonda comprensiva di presa tipo Schuko o di presa standard francese, da specificare al momento dell'ordine. La base è in fusione di ottone, disponibile nelle finiture ottone anticato, nichel e Rustic Silver™, a quattro uscite laterali, tutte con sezione da Ø 16 mm. La parte superiore della scatola è in gres ceramico. L'articolo va integrato con componenti qui di seguito descritti e da ordinare a parte:

- art. **TAP.16** per chiudere le uscite non utilizzate
- art. **CIL.16** per utilizzare le uscite da Ø 16 mm
- art. **CIL.10** integrato con l'articolo **RID.2** per utilizzare le uscite da Ø 16 mm ridotte a sezione Ø 10 mm

Round box with ceramic-gres cover and cast-brass base, available in aged brass, nickel and Rustic Silver™ finishes, with four lateral outputs 16 mm diam. section. The cover includes Schuko socket or French standard socket, to specify at the time of order. The article can be connected to all those accessories, here described, used for making up the box, to be ordered separately:

- art. **TAP.16** to close the unused outputs
- art. **CIL.16** for outputs with the 16 mm diam. section
- art. **CIL.10** with art. **RID.2** for outputs with the 16 mm diam. section reduced to 10 mm diam.



76/SCHUKO **76/FRA**

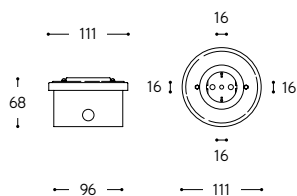

ARTICOLO ITEM	V	A	PESO GR. WEIGHT GR.	VOL. IN M ³ VOL. IN M ³	PEZZI IMBALLO OUTER BOX	FASCIA PREZZO PRICE RANGE
76/SCHUKO Ottone / Brass						B38
76/SCHUKO.NI Nichel / Nickel	250	16	870	0,01	1	B38
76/SCHUKO.RS Rustic Silver™						B44
76/FRA Ottone / Brass						B38
76/FRA.NI Nichel / Nickel	230	16	870	0,01	1	B38
76/FRA.RS Rustic Silver™						B44

Scatola rotonda Round box

Scatola rotonda per due prese e/o interruttori in fusione di ottone, disponibile nelle finiture ottone anticato, nichel e Rustic Silver™. La base è a quattro uscite laterali, tutte con sezione da Ø 16 mm. La scatola è predisposta per apparecchi della serie Vimar 8000 che non sono forniti con l'articolo.

L'articolo va integrato con componenti qui di seguito descritti e da ordinare a parte:

- art. **TAP.16** per chiudere le uscite non utilizzate
- art. **CIL.16** per utilizzare le uscite da Ø 16 mm
- art. **CIL.10** integrato con l'articolo **RID.2** per utilizzare le uscite da Ø 16 mm ridotte a sezione Ø 10 mm

Round box in cast-brass, available in aged brass, nickel and Rustic Silver™ finishes, with four lateral outputs 16 mm diam. section. The cover is arranged for two switches and/or plugs. The box is arranged for plugs/switches Vimar 8000 not here included. The article can be connected to all those accessories, here described, used for making up the box, to be ordered separately:

- art. **TAP.16** to close the unused outputs
- art. **CIL.16** for outputs with the 16 mm diam. section
- art. **CIL.10** with art. **RID.2** for outputs with the 16 mm diam. section reduced to 10 mm diam.

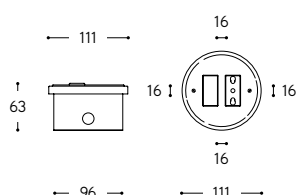

ARTICOLO ITEM	PESO GR. WEIGHT GR.	VOL. IN M ³ VOL. IN M ³	PEZZI IMBALLO OUTER BOX	FASCIA PREZZO PRICE RANGE
77 Ottone / Brass				B40
77.NI Nichel / Nickel	1.150	0,01	1	B40
77.RS Rustic Silver™				B49

Scatola rotonda Round box

Scatola rotonda comprensiva di presa tipo Schuko o di presa standard francese, da specificare al momento dell'ordine. L'articolo è completamente in fusione di ottone, disponibile nelle finiture ottone anticato, nichel e Rustic Silver™. La base è a quattro uscite laterali, tutte con sezione da Ø 16 mm. L'articolo va integrato con componenti qui di seguito descritti e da ordinare a parte:

- art. **TAP.16** per chiudere le uscite non utilizzate
 - art. **CIL.16** per utilizzare le uscite da Ø 16 mm
 - art. **CIL.10** integrato con l'articolo **RID.2** per utilizzare le uscite da Ø 16 mm ridotte a sezione Ø 10 mm
- Round box in cast-brass, available in aged brass, nickel and Rustic Silver™ finishes, with four lateral outputs 16 mm diam. section. The cover includes Schuko socket or French standard socket, to specify at the time of order. The article can be connected to all those accessories, here described, used for making up the box, to be ordered separately:
- art. **TAP.16** to close the unused outputs
 - art. **CIL.16** for outputs with the 16 mm diam. section
 - art. **CIL.10** with art. **RID.2** for outputs with the 16 mm diam. section reduced to 10 mm diam.



77/SCHUKO 77/FRA

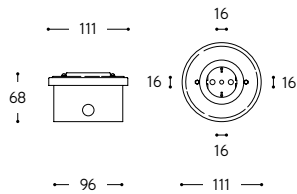

ARTICOLO ITEM	V	A	PESO GR. WEIGHT GR.	VOL. IN M ³ VOL. IN M ³	PEZZI IMBALLO OUTER BOX	FASCIA PREZZO PRICE RANGE
77/SCHUKO Ottone / Brass						B41
77/SCHUKO.NI Nichel / Nickel	250	16	1.180	0,01	1	B41
77/SCHUKO.RS Rustic Silver™						B49
77/FRA Ottone / Brass						B41
77/FRA.NI Nichel / Nickel	230	16	1.180	0,01	1	B41
77/FRA.RS Rustic Silver™						B49

Scatola rotonda Round box

Scatola rotonda per interruttore/deviatore rotativo compreso nell'articolo. La base è in fusione di ottone, disponibile nelle finiture ottone anticato, nichel e Rustic Silver™, a quattro uscite laterali, tutte con sezione da Ø 16 mm. La parte superiore della scatola è in gres ceramico. L'articolo va integrato con componenti qui di seguito descritti e da ordinare a parte:

- art. **TAP.16** per chiudere le uscite non utilizzate
- art. **CIL.16** per utilizzare le uscite da Ø 16 mm
- art. **CIL.10** integrato con l'articolo **RID.2** per utilizzare le uscite da Ø 16 mm ridotte a sezione Ø 10 mm

Round box with ceramic-gres cover and cast-brass base, available in aged brass, nickel and Rustic Silver™ finishes, with our lateral outputs 16 mm diam. section. The cover is arranged for a single/two ways rotative switch here included. The article can be connected to all those accessories, here described, used for making up the box, to be ordered separately:

- art. **TAP.16** to close the unused outputs
- art. **CIL.16** for outputs with the 16 mm diam. section
- art. **CIL.10** with art. **RID.2** for outputs with the 16 mm diam. section reduced to 10 mm diam.

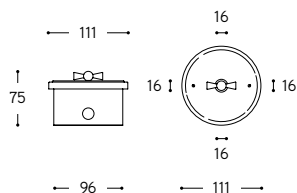

ARTICOLO ITEM	V	A	PESO GR. WEIGHT GR.	VOL. IN M ³ VOL. IN M ³	PEZZI IMBALLO OUTER BOX	FASCIA PREZZO PRICE RANGE
78 Ottone / Brass						B37
78.NI Nichel / Nickel	250	10	900	0,01	1	B37
78.RS Rustic Silver™						B44

Scatola rotonda Round box

Scatola rotonda per interruttore/deviatore rotativo compreso nell'articolo, in fusione di ottone, disponibile nelle finiture ottone anticato, nichel e Rustic Silver™. La base è a quattro uscite laterali, tutte con sezione da Ø 16 mm. L'articolo va integrato con componenti qui di seguito descritti e da ordinare a parte:

- art. **TAP.16** per chiudere le uscite non utilizzate
- art. **CIL.16** per utilizzare le uscite da Ø 16 mm
- art. **CIL.10** integrato con l'articolo **RID.2** per utilizzare le uscite da Ø 16 mm ridotte a sezione Ø 10 mm

Round box in cast-brass, available in aged brass, nickel and Rustic Silver™ finishes, with four lateral outputs 16 mm diam. section. The cover is arranged for a single/two ways rotative switch here included. The article can be connected to all those accessories, here described, used for making up the box, to be ordered separately:

- art. **TAP.16** to close the unused outputs
- art. **CIL.16** for outputs with the 16 mm diam. section
- art. **CIL.10** with art. **RID.2** for outputs with the 16 mm diam. section reduced to 10 mm diam.

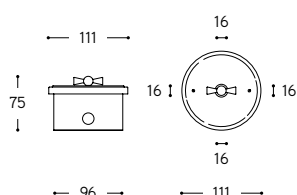

ARTICOLO ITEM	V	A	PESO GR. WEIGHT GR.	VOL. IN M ³ VOL. IN M ³	PEZZI IMBALLO OUTER BOX	FASCIA PREZZO PRICE RANGE
79 Ottone / Brass						B40
79.NI Nichel / Nickel	250	10	1.260	0,01	1	B40
79.RS Rustic Silver™						B49

Scatola rettangolare Rectangular box

Scatola rettangolare per due prese e/o interruttori ed un interruttore/deviatore rotativo. La base è in fusione di ottone, disponibile nelle finiture ottone anticato, nichel e Rustic Silver™, a sei uscite laterali, tutte con sezione da Ø 20 mm. La parte superiore della scatola è in gres ceramico. La scatola è predisposta per apparecchi della serie Vimar 8000 che non sono forniti con l'articolo. L'interruttore rotativo è invece compreso nell'articolo. L'articolo va integrato con componenti qui di seguito descritti e da ordinare a parte:

- art. **TAP.20** per chiudere le uscite non utilizzate
- art. **CIL.20** per utilizzare le uscite da Ø 20 mm
- art. **CIL.16** integrato con art. **RID.1** per utilizzare le uscite da Ø 20 mm ridotte a sezione Ø 16 mm
- art. **CIL.10** integrato con gli articoli **RID.1** e **RID.2** per utilizzare le uscite da Ø 20 mm ridotte a sezione Ø 10 mm

Rectangular box with ceramic-gres cover and cast-brass base, available in aged brass, nickel and Rustic Silver™ finishes, with six lateral outputs 20 mm diam. section. The cover is arranged for two switches and/or plugs and a single/two ways rotative switch. The box is arranged for plugs/switches Vimar 8000 not here included. Rotative switch is here included. The article can be connected to all those accessories, here described, used for making up the box, to be ordered separately:

- art. **TAP.20** to close the unused outputs
- art. **CIL.20** for outputs with the 20 mm diam. section
- art. **CIL.16** with art. **RID.1** for outputs with the 20 mm diam. section reduced to 16 mm diam.
- art. **CIL.10** with articles **RID.1** and **RID.2** for outputs with the 20 mm diam. section reduced to 10 mm diam.

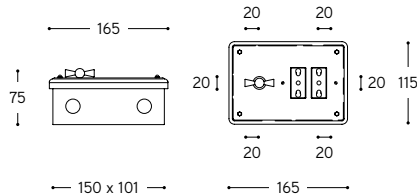

ARTICOLO ITEM	V	A	PESO GR. WEIGHT GR.	VOL. IN M ³ VOL. IN M ³	PEZZI IMBALLO OUTER BOX	FASCIA PREZZO PRICE RANGE
96 Ottone / Brass						B44
96.NI Nichel / Nickel	250	10	2.020	0,01	1	B44
96.RS Rustic Silver™						B51

Scatola rettangolare Rectangular box

Scatola rettangolare comprensiva di presa tipo Schuko o di presa standard francese, da specificare al momento dell'ordine. La scatola è inoltre predisposta per apparecchi della serie Vimar 8000 che non sono forniti con l'articolo. La base è in fusione di ottone, disponibile nelle finiture ottone anticato, nichel e Rustic Silver™, a 6 uscite laterali, tutte con sezione da Ø 20 mm. La parte superiore della scatola è in gres ceramico. L'articolo va integrato con componenti qui di seguito descritti e da ordinare a parte:

- art. **TAP.20** per chiudere le uscite non utilizzate
- art. **CIL.20** per utilizzare le uscite da Ø 20 mm
- art. **CIL.16** integrato con art. **RID.1** per utilizzare le uscite da Ø 20 mm ridotte a sezione Ø 16 mm
- art. **CIL.10** integrato con gli articoli **RID.1** e **RID.2** per utilizzare le uscite da Ø 20 mm ridotte a sezione Ø 10 mm

Rectangular box with ceramic cover and cast-brass base, available in aged brass, nickel and Rustic Silver™ finishes, with 6 lateral outputs 20 mm. diam. section. The cover includes Schuko socket or French standard socket, to specify at the time of order. It's also arranged for plugs/switches Vimar 8000, not included. The article can be connected to all those accessories, here described, used for making up the box, to be ordered separately:

- art. **TAP.20** to close the unused outputs
- art. **CIL.20** for outputs with the 20 mm diam. section
- art. **CIL.16** with art. **RID.1** for outputs with the 20 mm diam. section reduced to 16 mm diam.
- art. **CIL.10** with articles **RID.1** and **RID.2** for outputs with the 20 mm diam. section reduced to 10 mm diam.

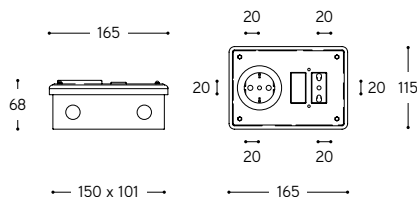

96/SCHUKO **96/FRA**

ARTICOLO ITEM	V	A	PESO GR. WEIGHT GR.	VOL. IN M ³ VOL. IN M ³	PEZZI IMBALLO OUTER BOX	FASCIA PREZZO PRICE RANGE
96/SCHUKO Ottone / Brass						B44
96/SCHUKO.NI Nichel / Nickel	250	16	2.060	0,01	1	B44
96/SCHUKO.RS Rustic Silver™						B51
96/FRA Ottone / Brass						B44
96/FRA.NI Nichel / Nickel	230	16	2.060	0,01	1	B44
96/FRA.RS Rustic Silver™						B51



Scatola rettangolare Rectangular box

Scatola rettangolare per due prese e/o interruttori ed un interruttore/deviatore rotativo. La scatola è in fusione di ottone, disponibile nelle finiture ottone anticato, nichel e Rustic Silver™, a sei uscite laterali, tutte con sezione da Ø 20 mm. La scatola è predisposta per apparecchi della serie Vimar 8000 che non sono forniti con l'articolo. L'interruttore rotativo è invece compreso nell'articolo. L'articolo va integrato con componenti qui di seguito descritti e da ordinare a parte:

- art. **TAP.20** per chiudere le uscite non utilizzate
- art. **CIL.20** per utilizzare le uscite da Ø 20 mm
- art. **CIL.16** integrato con art. **RID.1** per utilizzare le uscite da Ø 20 mm ridotte a sezione Ø 16 mm
- art. **CIL.10** integrato con gli articoli **RID.1** e **RID.2** per utilizzare le uscite da Ø 20 mm ridotte a sezione Ø 10 mm

Rectangular box in cast-brass, available in aged brass, nickel and Rustic Silver™ finishes, with six lateral outputs 20 mm diam. section. The cover is arranged for two switches and/or plugs and a single/two ways rotative switch. The box is arranged for plugs/switches Vimar 8000 not here included. Rotative switch is here included. The article can be connected to all those accessories, here described, used for making up the box, to be ordered separately:

- art. **TAP.20** to close the unused outputs
- art. **CIL.20** for outputs with the 20 mm diam. section
- art. **CIL.16** with art. **RID.1** for outputs with the 20 mm diam. section reduced to 16 mm diam.
- art. **CIL.10** with articles **RID.1** and **RID.2** for outputs with the 20 mm diam. section reduced to 10 mm diam.

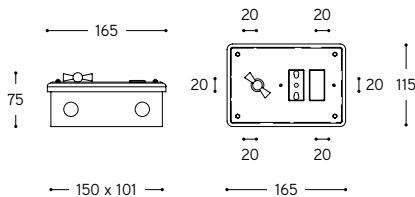

ARTICOLO ITEM	V	A	PESO GR. WEIGHT GR.	VOL. IN M³ VOL. IN M³	PEZZI IMBALLO OUTER BOX	FASCIA PREZZO PRICE RANGE
97 Ottone / Brass						B50
97.NI Nichel / Nickel	250	10	2.200	0,01	1	B50
97.RS Rustic Silver™						B64



Scatola rettangolare Rectangular box

Scatola rettangolare comprensiva di presa tipo Schuko o di presa standard francese, da specificare al momento dell'ordine. La scatola è inoltre predisposta per apparecchi della serie Vimar 8000 che non sono forniti con l'articolo. La scatola è in fusione di ottone, disponibile nelle finiture ottone anticato, nichel e Rustic Silver™, a 6 uscite laterali, tutte con sezione da Ø 20 mm. L'articolo va integrato con componenti qui di seguito descritti e da ordinare a parte:

- art. **TAP.20** per chiudere le uscite non utilizzate
- art. **CIL.20** per utilizzare le uscite da Ø 20 mm
- art. **CIL.16** integrato con art. **RID.1** per utilizzare le uscite da Ø 20 mm ridotte a sezione Ø 16 mm
- art. **CIL.10** integrato con gli articoli **RID.1** e **RID.2** per utilizzare le uscite da Ø 20 mm ridotte a sezione Ø 10 mm

Rectangular box in cast-brass, available in aged brass, nickel and Rustic Silver™ finishes, with 6 lateral outputs 20 mm. diam. section. The cover includes Schuko socket or French standard socket, to specify at the time of order. It's also arranged for plugs/switches Vimar 8000, not included. The article can be connected to all those accessories, here described, used for making up the box, to be ordered separately:

- art. **TAP.20** to close the unused outputs
- art. **CIL.20** for outputs with the 20 mm diam. section
- art. **CIL.16** with art. **RID.1** for outputs with the 20 mm diam. section reduced to 16 mm diam.
- art. **CIL.10** with articles **RID.1** and **RID.2** for outputs with the 20 mm diam. section reduced to 10 mm diam.

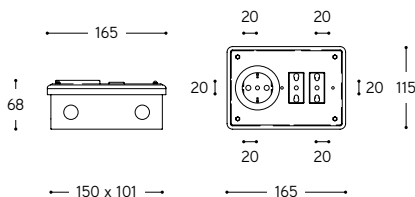

97/SCHUKO **97/FRA**

ARTICOLO ITEM	V	A	PESO GR. WEIGHT GR.	VOL. IN M³ VOL. IN M³	PEZZI IMBALLO OUTER BOX	FASCIA PREZZO PRICE RANGE
97/SCHUKO Ottone / Brass						B51
97/SCHUKO.NI Nichel / Nickel	250	16	2.230	0,01	1	B51
97/SCHUKO.RS Rustic Silver™						B64
97/FRA Ottone / Brass						B51
97/FRA.NI Nichel / Nickel	230	16	2.230	0,01	1	B51
97/FRA.RS Rustic Silver™						B64

Scatola rettangolare Rectangular box

Scatola rettangolare per quattro prese e/o interruttori. La base è in fusione di ottone, disponibile nelle finiture ottone anticato, nichel e Rustic Silver™, a sei uscite laterali, tutte con sezione da Ø 20 mm. La parte superiore della scatola è in gres ceramico. La scatola è predisposta per apparecchi della serie Vimar 8000 che non sono forniti con l'articolo. L'articolo va integrato con componenti qui di seguito descritti e da ordinare a parte:

- art. **TAP.20** per chiudere le uscite non utilizzate
- art. **CIL.20** per utilizzare le uscite da Ø 20 mm
- art. **CIL.16** integrato con art. **RID.1** per utilizzare le uscite da Ø 20 mm ridotte a sezione Ø 16 mm
- art. **CIL.10** integrato con gli articoli **RID.1** e **RID.2** per utilizzare le uscite da Ø 20 mm ridotte a sezione Ø 10 mm

Rectangular box with ceramic-gres cover and cast-brass base, available in aged brass, nickel and Rustic Silver™ finishes, with six lateral outputs 20 mm diam. section. The cover is arranged for four switches and/or plugs. The box is arranged for plugs/switches Vimar 8000 not here included. The article can be connected to all those accessories, here described, used for making up the box, to be ordered separately:

- art. **TAP.20** to close the unused outputs
- art. **CIL.20** for outputs with the 20 mm diam. section
- art. **CIL.16** with art. **RID.1** for outputs with the 20 mm diam. section reduced to 16 mm diam.
- art. **CIL.10** with articles **RID.1** and **RID.2** for outputs with the 20 mm diam. section reduced to 10 mm diam.

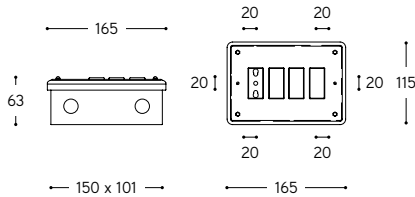

ARTICOLO ITEM	PESO GR. WEIGHT GR.	VOL. IN M ³ VOL. IN M ³	PEZZI IMBALLO OUTER BOX	FASCIA PREZZO PRICE RANGE
98 Ottone / Brass				B44
98.NI Nichel / Nickel	1.960	0,01	1	B44
98.RS Rustic Silver™				B51

Scatola rettangolare Rectangular box

Scatola rettangolare comprensiva di due prese tipo Schuko o standard francese, da specificare al momento dell'ordine. La base è in fusione di ottone, disponibile nelle finiture ottone anticato, nichel e Rustic Silver™, a 6 uscite laterali, tutte con sezione da Ø 20 mm. La parte superiore della scatola è in gres ceramico. L'articolo va integrato con componenti qui di seguito descritti e da ordinare a parte:

- art. **TAP.20** per chiudere le uscite non utilizzate
- art. **CIL.20** per utilizzare le uscite da Ø 20 mm
- art. **CIL.16** integrato con art. **RID.1** per utilizzare le uscite da Ø 20 mm ridotte a sezione Ø 16 mm
- art. **CIL.10** integrato con gli articoli **RID.1** e **RID.2** per utilizzare le uscite da Ø 20 mm ridotte a sezione Ø 10 mm

Rectangular box with ceramic cover and cast-brass base, available in aged brass, nickel and Rustic Silver™ finishes, with 6 lateral outputs 20 mm. diam. section. The cover includes two Schuko sockets or French standard sockets, to specify at the time of order. The article can be connected to all those accessories, here described, used for making up the box, to be ordered separately:

- art. **TAP.20** to close the unused outputs
- art. **CIL.20** for outputs with the 20 mm diam. section
- art. **CIL.16** with art. **RID.1** for outputs with the 20 mm diam. section reduced to 16 mm diam.
- art. **CIL.10** with articles **RID.1** and **RID.2** for outputs with the 20 mm diam. section reduced to 10 mm diam.

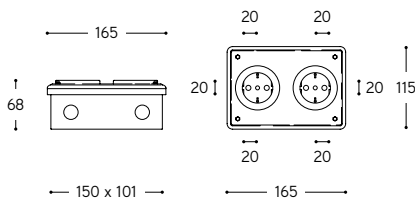

98/SCHUKO 98/FRA

ARTICOLO ITEM	V	A	PESO GR. WEIGHT GR.	VOL. IN M ³ VOL. IN M ³	PEZZI IMBALLO OUTER BOX	FASCIA PREZZO PRICE RANGE
98/SCHUKO Ottone / Brass						B48
98/SCHUKO.NI Nichel / Nickel	250	16	2.020	0,01	1	B48
98/SCHUKO.RS Rustic Silver™						B51
98/FRA Ottone / Brass						B48
98/FRA.NI Nichel / Nickel	230	16	2.020	0,01	1	B48
98/FRA.RS Rustic Silver™						B51



Scatola rettangolare Rectangular box

Scatola rettangolare per quattro prese e/o interruttori. La scatola è in fusione di ottone, disponibile nelle finiture ottone anticato, nichel e Rustic Silver™, a sei uscite laterali, tutte con sezione da Ø 20 mm. La scatola è predisposta per apparecchi della serie Vimar 8000 che non sono forniti con l'articolo. L'articolo va integrato con componenti qui di seguito descritti e da ordinare a parte:

- art. **TAP.20** per chiudere le uscite non utilizzate
- art. **CIL.20** per utilizzare le uscite da Ø 20 mm
- art. **CIL.16** integrato con art. **RID.1** per utilizzare le uscite da Ø 20 mm ridotte a sezione Ø 16 mm
- art. **CIL.10** integrato con gli articoli **RID.1** e **RID.2** per utilizzare le uscite da Ø 20 mm ridotte a sezione Ø 10 mm

Rectangular box in cast-brass, available in aged brass, nickel and Rustic Silver™ finishes, with six lateral outputs 20 mm diam. section. The cover is arranged for four switches and/or plugs. The box is arranged for plugs/switches Vimar 8000 not here included. The article can be connected to all those accessories, here described, used for making up the box, to be ordered separately:

- art. **TAP.20** to close the unused outputs
- art. **CIL.20** for outputs with the 20 mm diam. section
- art. **CIL.16** with art. **RID.1** for outputs with the 20 mm diam. section reduced to 16 mm diam.
- art. **CIL.10** with articles **RID.1** and **RID.2** for outputs with the 20 mm diam. section reduced to 10 mm diam.

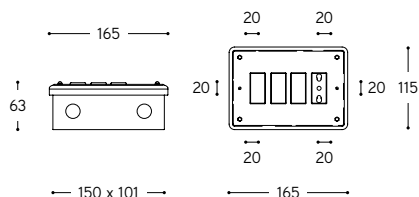

ARTICOLO ITEM	PESO GR. WEIGHT GR.	VOL. IN M ³ VOL. IN M ³	PEZZI IMBALLO OUTER BOX	FASCIA PREZZO PRICE RANGE
99 Ottone / Brass				B50
99.NI Nichel / Nickel	2.060	0,01	1	B50
99.RS Rustic Silver™				B64



Scatola rettangolare Rectangular box

Scatola rettangolare comprensiva di due prese tipo Schuko o standard francese, da specificare al momento dell'ordine. La scatola è in fusione di ottone, disponibile nelle finiture ottone anticato, nichel e Rustic Silver™, a 6 uscite laterali, tutte con sezione da Ø 20 mm. L'articolo va integrato con componenti qui di seguito descritti e da ordinare a parte:

- art. **TAP.20** per chiudere le uscite non utilizzate
- art. **CIL.20** per utilizzare le uscite da Ø 20 mm
- art. **CIL.16** integrato con art. **RID.1** per utilizzare le uscite da Ø 20 mm ridotte a sezione Ø 16 mm
- art. **CIL.10** integrato con gli articoli **RID.1** e **RID.2** per utilizzare le uscite da Ø 20 mm ridotte a sezione Ø 10 mm

Rectangular box in cast-brass, available in aged brass, nickel and Rustic Silver™ finishes, with 6 lateral outputs 20 mm. diam. section. The cover includes two Schuko sockets or French standard sockets, to specify at the time of order. The article can be connected with all those accessories, here described, used for making up the box, to be ordered separately:

- art. **TAP.20** to close the unused outputs
- art. **CIL.20** for outputs with the 20 mm diam. section
- art. **CIL.16** with art. **RID.1** for outputs with the 20 mm diam. section reduced to 16 mm diam.
- art. **CIL.10** with articles **RID.1** and **RID.2** for outputs with the 20 mm diam. section reduced to 10 mm diam.

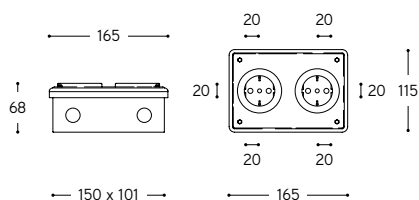

99/SCHUKO **99/FRA**

ARTICOLO ITEM	V	A	PESO GR. WEIGHT GR.	VOL. IN M ³ VOL. IN M ³	PEZZI IMBALLO OUTER BOX	FASCIA PREZZO PRICE RANGE
99/SCHUKO Ottone / Brass						B52
99/SCHUKO.NI Nichel / Nickel	250	16	2.120	0,01	1	B52
99/SCHUKO.RS Rustic Silver™						B64
99/FRA Ottone / Brass						B52
99/FRA.NI Nichel / Nickel	230	16	2.120	0,01	1	B52
99/FRA.RS Rustic Silver™						B64



Scatola rettangolare Rectangular box

Scatola rettangolare comprensiva di 6 prese tipo Schuko o standard francese, da specificare al momento dell'ordine. La scatola è in fusione di ottone, disponibile nelle finiture ottone anticato, nichel e Rustic Silver™, a 6 uscite laterali, tutte con sezione da \varnothing 20 mm. L'articolo va integrato con componenti qui di seguito descritti e da ordinare a parte:

- art. **TAP.20** per chiudere le uscite non utilizzate
- art. **CIL.20** per utilizzare le uscite da \varnothing 20 mm
- art. **CIL.16** integrato con art. **RID.1** per utilizzare le uscite da \varnothing 20 mm ridotte a sezione \varnothing 16 mm
- art. **CIL.10** integrato con gli articoli **RID.1** e **RID.2** per utilizzare le uscite da \varnothing 20 mm ridotte a sezione \varnothing 10 mm

Rectangular box in cast-brass, available in aged brass, nickel and Rustic Silver™ finishes, with 6 lateral outputs 20 mm. diam. section. The cover includes six Schuko sockets or French standard sockets, to specify at the time of order. The article can be connected with all those accessories, here described, used for making up the box, to be ordered separately:

- art. **TAP.20** to close the unused outputs
- art. **CIL.20** for outputs with the 20 mm diam. section
- art. **CIL.16** with art. **RID.1** for outputs with the 20 mm diam. section reduced to 16 mm diam.
- art. **CIL.10** with articles **RID.1** and **RID.2** for outputs with the 20 mm diam. section reduced to 10 mm diam.

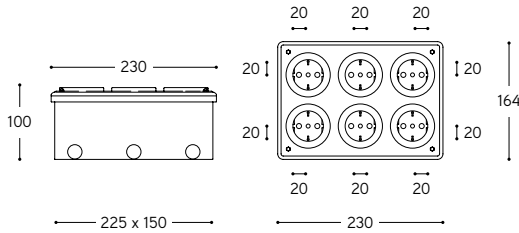

SD100/SCHUKO SD100/FRA

ARTICOLO ITEM		V	A	PESO GR. WEIGHT GR.	VOL. IN M ³ VOL. IN M ³	PEZZI IMBALLO OUTER BOX	FASCIA PREZZO PRICE RANGE
SD100/SCHUKO	Ottone / Brass						B72
SD100/SCHUKO.NI	Nichel / Nickel	250	16	6.350	0,02	1	B72
SD100/SCHUKO.RS	Rustic Silver™						B81
SD100/FRA	Ottone / Brass						B72
SD100/FRA.NI	Nichel / Nickel	230	16	6.350	0,02	1	B72
SD100/FRA.RS	Rustic Silver™						B81

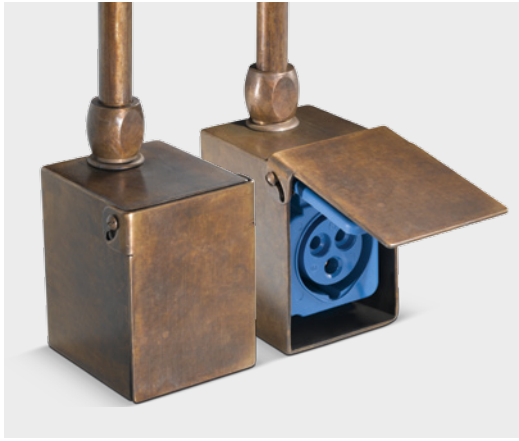

Scatola con presa industriale Box with industrial socket

Scatola disponibile nelle finiture ottone anticato, nichel e Rustic Silver™ con un'unica uscita superiore, sezione da Ø 16 mm comprensiva di raccordo CIL.16. La scatola è comprensiva di presa industriale da parete, protetta, bassa tensione, in contenitore in materiale termoindurente, IP44 50-60Hz 230V, 2P+T.

Box available in aged brass, nickel and Rustic Silver™ finishes, with a single superior output 16 mm. diam. section including the connection CIL.16. The box contains protected wall mounted industrial socket-outlets, low voltage, in thermosetting (GRP) material enclosure, IP44 50-60Hz 230V, 2P+T.

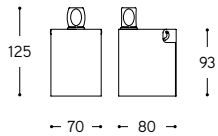

ARTICOLO ITEM	PESO GR. WEIGHT GR.	VOL. IN M ³ VOL. IN M ³	PEZZI IMBALLO OUTER BOX	FASCIA PREZZO PRICE RANGE
SC101 Ottone / Brass				B51
SC101.NI Nichel / Nickel	1.650	0,02	1	B51
SC101.RS Rustic Silver™				B66



Scatola con presa tipo Schuko Box with Schuko socket

Scatola disponibile nelle finiture ottone anticato, nichel e Rustic Silver™ con un'unica uscita superiore, sezione da Ø 16 mm comprensiva di raccordo CIL.16. La scatola è comprensiva di presa da incasso, in contenitore protetto in materiale termoindurente 250V-IP44, 2P+ T 10/16A UNEL passo 19mm. tipo Schuko.

Box available in aged brass, nickel and Rustic Silver™ finishes, with a single superior output 16 mm. diam. section including the connection CIL.16. The box contains wall-mounted socket-outlet, in protected enclosure in thermosetting (GPR) material 250V-IP44, 2P+ T 10/16A UNEL pitch 19 mm. Schuko.

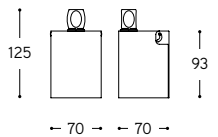

ARTICOLO ITEM	PESO GR. WEIGHT GR.	VOL. IN M ³ VOL. IN M ³	PEZZI IMBALLO OUTER BOX	FASCIA PREZZO PRICE RANGE
SC102/S Ottone / Brass				B46
SC102/S.NI Nichel / Nickel	1.650	0,02	1	B46
SC102/S.RS Rustic Silver™				B60



Scatola con presa norma franco/belga Box with french-belgian standard socket

Scatola disponibile nelle finiture ottone anticato, nichel e Rustic Silver™ con un'unica uscita superiore, sezione da Ø 16 mm comprensiva di raccordo CIL.16. La scatola è comprensiva di presa norma franco-belga, 230V-IP44, 2P+ T 16A.

Box available in aged brass, nickel and Rustic Silver™ finishes, with a single superior output 16 mm. diam. section including the connection CIL.16. The box contains french-belgian socket-outlet, 230V-IP44, 2P+ T 16A.

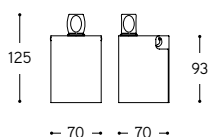

ARTICOLO ITEM	PESO GR. WEIGHT GR.	VOL. IN M ³ VOL. IN M ³	PEZZI IMBALLO OUTER BOX	FASCIA PREZZO PRICE RANGE
SC102/FRA Ottone / Brass				B46
SC102/FRA.NI Nichel / Nickel	1.650	0,02	1	B46
SC102/FRA.RS Rustic Silver™				B60



Scatola con interruttore da parete

Box with switch

Scatola disponibile nelle finiture ottone anticato, nichel e Rustic Silver™ con un'unica uscita superiore, sezione da Ø 16 mm comprensiva di raccordo CIL.16. La scatola è comprensiva di interruttore in contenitore stagno da parete in materiale termoindurente, IP67, 16A 250V - 10A 400V.

Box available in aged brass, nickel and Rustic Silver™ finishes, with a single superior output 16 mm. diam. section including the connection CIL.16. The box contains switch in watertight wall mounting enclosure in thermosetting (GRP) material IP67, 16A 250V - 10A 400V.

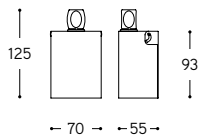

ARTICOLO ITEM	PESO GR. WEIGHT GR.	VOL. IN M ³ VOL. IN M ³	PEZZI IMBALLO OUTER BOX	FASCIA PREZZO PRICE RANGE
SC103 Ottone / Brass				B51
SC103.NI Nichel / Nickel	1.700	0,02	1	B51
SC103.RS Rustic Silver™				B66



Scatola con deviatore

Box with two-way switch

Scatola disponibile nelle finiture ottone anticato, nichel e Rustic Silver™ con un'unica uscita superiore, sezione da Ø 16 mm comprensiva di raccordo CIL.16. La scatola è comprensiva di deviatore in contenitore stagno da parete in materiale termoindurente, IP67, 16A 250V - 10A 400V.

Box available in aged brass, nickel and Rustic Silver™ finishes, with a single superior output 16 mm. diam. section including the connection CIL.16. The box contains two-way switch in watertight wall mounting enclosure in thermosetting (GRP) material IP67, 16A 250V - 10A 400V.

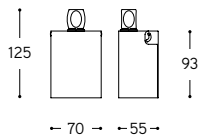

ARTICOLO ITEM	PESO GR. WEIGHT GR.	VOL. IN M ³ VOL. IN M ³	PEZZI IMBALLO OUTER BOX	FASCIA PREZZO PRICE RANGE
SC104 Ottone / Brass				B58
SC104.NI Nichel / Nickel	1.700	0,02	1	B58
SC104.RS Rustic Silver™				B71

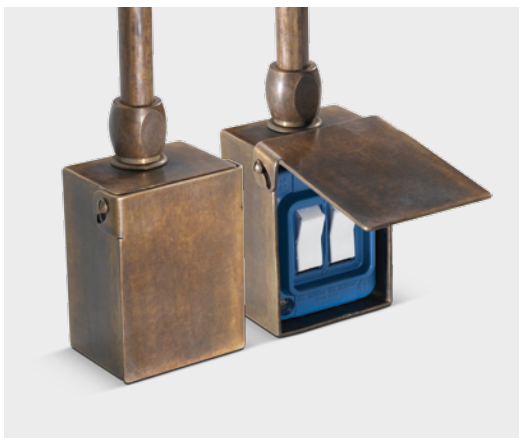

Scatola con commutatore

Box with selector switch

Scatola disponibile nelle finiture ottone anticato, nichel e Rustic Silver™ con un'unica uscita superiore, sezione da Ø 16 mm comprensiva di raccordo CIL.16. La scatola è comprensiva di commutatore in contenitore stagno da parete in materiale termoindurente, IP67 16A 250V - 10A 400V.

Box available in aged brass, nickel and Rustic Silver™ finishes, with a single superior output 16 mm. diam. section including the connection CIL.16. The box contains selector switch in watertight wall mounting enclosure in thermosetting (GRP) material IP67, 16A 250V - 10A 400V.

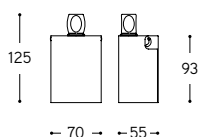

ARTICOLO ITEM	PESO GR. WEIGHT GR.	VOL. IN M ³ VOL. IN M ³	PEZZI IMBALLO OUTER BOX	FASCIA PREZZO PRICE RANGE
SC105 Ottone / Brass				B59
SC105.NI Nichel / Nickel	1.700	0,02	1	B59
SC105.RS Rustic Silver™				B72

Raccordi e supporti

Connections and accessories

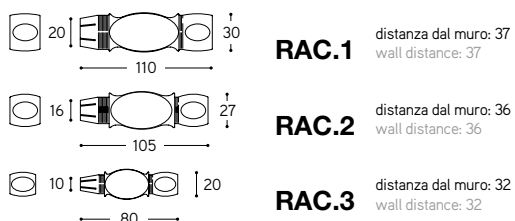
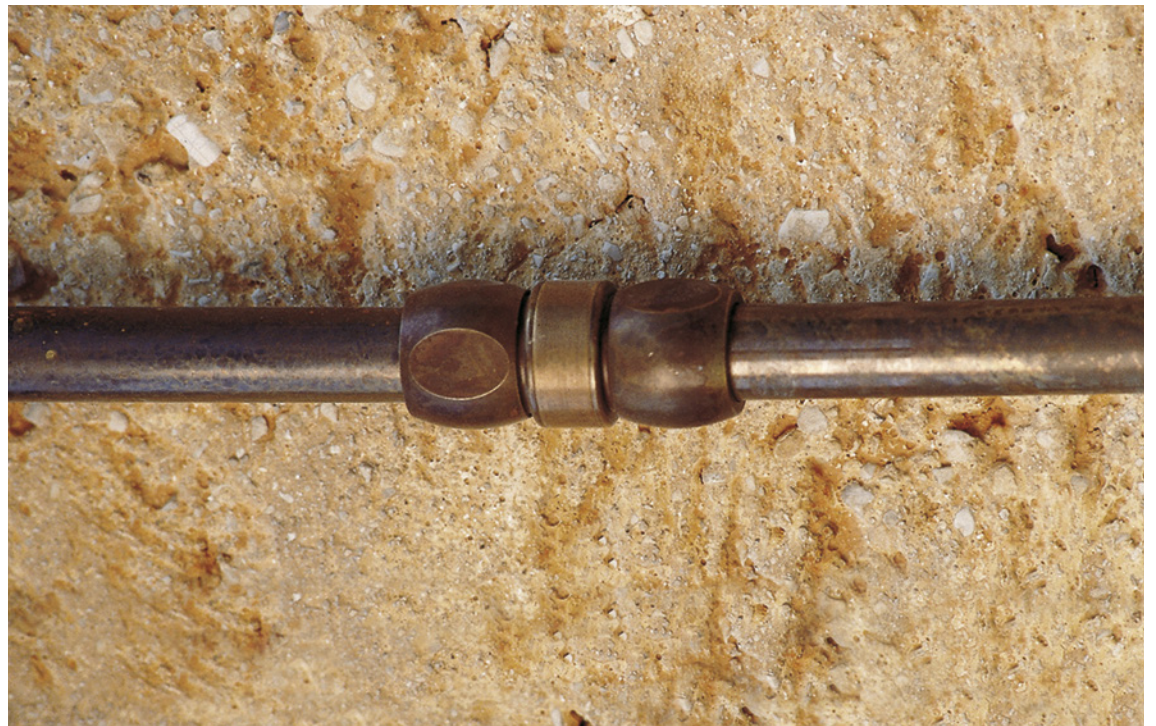

Raccordo a muro per canaletta Wall connection for external conduit

Raccordo per canaletta esterna con sezione da Ø 20, 16, 10 mm, fissato al muro con apposito tassello. È composto da un corpo centrale in fusione di ottone e da due olive laterali in ottone tornito. L'articolo è disponibile nelle finiture ottone anticato, nichel e Rustic Silver™. È autobloccante e permette di collegare tra loro tubi ricurvi, o tubi lineari con tubi ricurvi.

Connection for external conduit with section 20, 16, 10 mm diam, fixed to wall with special plug. Consists of a central body in cast brass and two side knobs in turned brass. The item is available in aged brass, nickel and Rustic Silver™ finishes. Self-locking for connecting together the bent tubes, and straight tubes with bent tubes.

ARTICOLO ITEM	PESO GR. WEIGHT GR.	VOL. IN M ³ VOL. IN M ³	PEZZI IMBALLO OUTER BOX	FASCIA PREZZO PRICE RANGE
RAC.1 Ottone / Brass				B35
RAC.1.NI Nichel / Nickel	394	0,0005	1	B35
RAC.1.RS Rustic Silver™				B38
RAC.2 Ottone / Brass				B34
RAC.2.NI Nichel / Nickel	338	0,0005	1	B34
RAC.2.RS Rustic Silver™				B38
RAC.3 Ottone / Brass				B27
RAC.3.NI Nichel / Nickel	168	0,0002	1	B27
RAC.3.RS Rustic Silver™				B33

Raccordo volante Flying connector

Raccordo volante con sezione da Ø 20, 16, 10 mm composto da una ghiera centrale e da due olive laterali entrambi in ottone tornito, disponibile nelle finiture ottone anticato, nichel e Rustic Silver™. È autobloccante e permette di collegare tra loro tubi in ottone e proseguire l'impianto elettrico esterno. Non si fissa al muro.

Flying connector with section 20, 16, 10 mm diam. consisting of central ring nut and two side knobs, both in turned brass, available in aged brass, nickel and Rustic Silver™ finishes. Self-locking for connecting brass tubes together and continuing the external electrical system. No wall fixing.

ARTICOLO ITEM	PESO GR. WEIGHT GR.	VOL. IN M ³ VOL. IN M ³	PEZZI IMBALLO OUTER BOX	FASCIA PREZZO PRICE RANGE
VOL.1 Ottone / Brass				B22
VOL.1.NI Nichel / Nickel	222	0,0002	1	B22
VOL.1.RS Rustic Silver™				B28
VOL.2 Ottone / Brass				B21
VOL.2.NI Nichel / Nickel	189	0,0002	1	B21
VOL.2.RS Rustic Silver™				B27
VOL.3 Ottone / Brass				B18
VOL.3.NI Nichel / Nickel	116	0,0002	1	B18
VOL.3.RS Rustic Silver™				B23

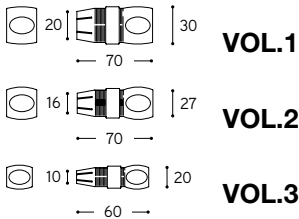

Supporto a muro Wall support

Supporto a muro in fusione di ottone, disponibile nelle finiture ottone anticato, nichel e Rustic Silver™, per passaggio della canaletta esterna. Permette di sostenere il tubo in ottone su lunghi tratti rettilinei. Si fissa al muro con apposito tassello. La canaletta si blocca stringendo due viti.

Wall support in cast brass, available in aged brass, nickel and Rustic Silver™ finishes, for passage of external raceway. Supports the brass tube in long, straight sections. Fixed to wall with special plug. The raceway is clamped by tightening two screws.

ARTICOLO ITEM	PESO GR. WEIGHT GR.	VOL. IN M ³ VOL. IN M ³	PEZZI IMBALLO OUTER BOX	FASCIA PREZZO PRICE RANGE
SUP.1 Ottone / Brass				B31
SUP.1.NI Nichel / Nickel	173	0,0002	1	B31
SUP.1.RS Rustic Silver™				B34
SUP.2 Ottone / Brass				B28
SUP.2.NI Nichel / Nickel	144	0,0002	1	B28
SUP.2.RS Rustic Silver™				B33
SUP.3 Ottone / Brass				B25
SUP.3.NI Nichel / Nickel	97	0,0002	1	B25
SUP.3.RS Rustic Silver™				B32

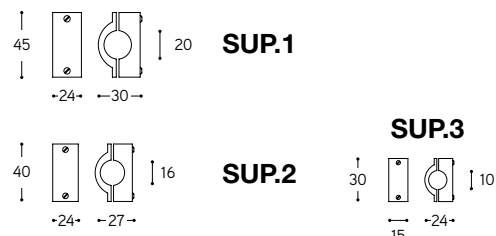

Raccordo Connection

Raccordo in ottone tornito con sezione da Ø 20, 16, 10 mm utilizzato per collegare il tubo in ottone per l'impianto esterno con tutte le scatole di derivazione, le basi per applique ed i rosoni. L'articolo è disponibile nelle finiture ottone anticato, nichel e Rustic Silver™. Le basi per applique e i rosoni da soffitto sono predisposti per i raccordi da 16 mm e 10 mm.

Connection in turned brass with section 20, 16, 10 mm diam. Used to connect the brass tube for external system to all the junction boxes, the bases for wall lamps and the ceiling roses. The item is available in aged brass, nickel and Rustic Silver™ finishes. The bases for wall lamps and ceiling roses for ceiling lamps are arranged for connections with section 16, 10 mm diam.

ARTICOLO ITEM	PESO GR. WEIGHT GR.	VOL. IN M ³ VOL. IN M ³	PEZZI IMBALLO OUTER BOX	FASCIA PREZZO PRICE RANGE
CIL.20 Ottone / Brass				B11
CIL.20.NI Nichel / Nickel	140	0,0001	1	B11
CIL.20.RS Rustic Silver™				B15
CIL.16 Ottone / Brass				B9
CIL.16.NI Nichel / Nickel	128	0,0001	1	B9
CIL.16.RS Rustic Silver™				B13
CIL.10 Ottone / Brass				B7
CIL.10.NI Nichel / Nickel	90	0,0001	1	B7
CIL.10.RS Rustic Silver™				B10

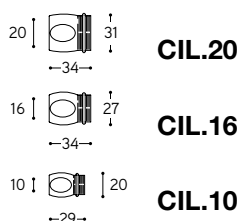



Riduzione Adapter

Riduzione in ottone tornito da applicare alle scatole di derivazione alle basi per applique ed ai rosoni per ridurre il diametro del foro d'entrata per l'impianto esterno da Ø 20 mm a Ø 16 mm, e da Ø 16 mm a Ø 10 mm. L'articolo è disponibile nelle finiture ottone anticato, nichel e Rustic Silver™.

Adapter in turned brass for application to junction boxes, bases for wall lamps and ceiling roses to reduce the inlet hole diameter for the external system from 20 mm diam. to 16 mm diam. and from 16 mm diam. to 10 mm diam. The item is available in aged brass, nickel and Rustic Silver™ finishes.

ARTICOLO ITEM	PESO GR. WEIGHT GR.	VOL. IN M ³ VOL. IN M ³	PEZZI IMBALLO OUTER BOX	FASCIA PREZZO PRICE RANGE
RID.1 Ottone / Brass				B2
RID.1.NI Nichel / Nickel	60	0,0001	1	B2
RID.1.RS Rustic Silver™				B4
RID.2 Ottone / Brass				B1
RID.2.NI Nichel / Nickel	73	0,0001	1	B1
RID.2.RS Rustic Silver™				B3

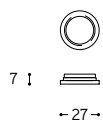
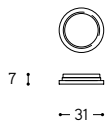
RID.1**RID.2**

Tappo / Cap

Tappo in ottone tornito usato per chiudere le uscite da Ø 20, 16 e 10 mm di scatole di derivazione, interruttori, prese, basi per applique e rosoni da soffitto. L'articolo è disponibile nelle finiture ottone anticato, nichel e Rustic Silver™. L'articolo è già incluso nei rosoni e nelle basi per applique (entrambi predisposti per due uscite da Ø 10 mm e due uscite da Ø 16 mm). È invece da ordinare a parte per chiudere le uscite non utilizzate delle scatole di derivazione, interruttori e prese che servono a realizzare un impianto elettrico su canaletta.

Cap in turned brass used to cap off Ø 20, 16 and 10 mm openings in junction boxes, switches, sockets and canopies. The item is available in aged brass, nickel and Rustic Silver™ finishes. The article is included with pendants roses and sconces bases (both arranged with two Ø 10 mm openings and two Ø 16 mm openings). It must be ordered separately to cap off unused openings in junction boxes, switches or sockets that are compatible with l'Impianto system.

ARTICOLO ITEM	PESO GR. WEIGHT GR.	VOL. IN M ³ VOL. IN M ³	PEZZI IMBALLO OUTER BOX	FASCIA PREZZO PRICE RANGE
TAP.20 Ottone / Brass				B2
TAP.20.NI Nichel / Nickel	90	0,0001	1	B2
TAP.20.RS Rustic Silver™				B4
TAP.16 Ottone / Brass				B2
TAP.16.NI Nichel / Nickel	70	0,0001	1	B2
TAP.16.RS Rustic Silver™				B3
TAP.10 Ottone / Brass				B1
TAP.10.NI Nichel / Nickel	60	0,0001	1	B1
TAP.10.RS Rustic Silver™				B2

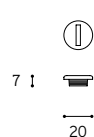
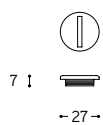
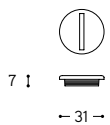
TAP.20**TAP.16****TAP.10**

Tubo lineare Straight tube

Tubo lineare in ottone per impianto elettrico esterno con sezione da Ø 20, 16 e 10 mm. L'articolo è disponibile nelle finiture ottone anticato, nichel e Rustic Silver™.

Brass straight tube for external electrical system with section 20, 16 and 10 mm diam. The item is available in aged brass, nickel and Rustic Silver™ finishes.

ARTICOLO ITEM	PESO GR. WEIGHT GR.	VOL. IN M ³ VOL. IN M ³	PEZZI IMBALLO OUTER BOX	FASCIA PREZZO PRICE RANGE
LIN.1 Ottone / Brass				B30
LIN.1.NI Nichel / Nickel	1.428	0,02	1	B30
LIN.1.RS Rustic Silver™				B33
LIN.2 Ottone / Brass				B24
LIN.2.NI Nichel / Nickel	1.352	0,02	1	B24
LIN.2.RS Rustic Silver™				B31
LIN.3 Ottone / Brass				B20
LIN.3.NI Nichel / Nickel	1.148	0,02	1	B20
LIN.3.RS Rustic Silver™				B24

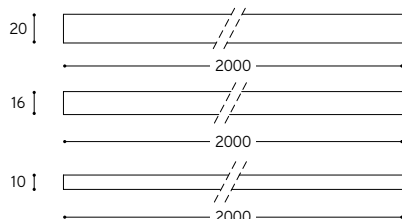



Tubo curvo Bent tube

Tubo curvo in ottone per impianto elettrico esterno con sezione da Ø 20, 16 e 10 mm. L'articolo è disponibile nelle finiture ottone anticato, nichel e Rustic Silver™.

Brass bent tube for external electrical system with section 20, 16 and 10 mm diam. The item is available in aged brass, nickel and Rustic Silver™ finishes.

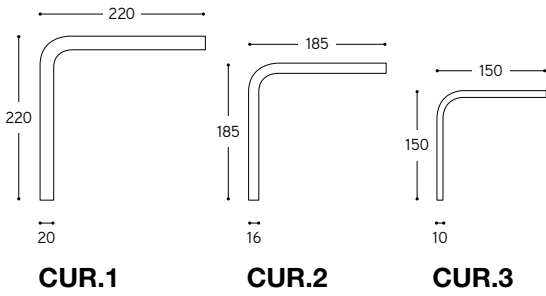

ARTICOLO ITEM	PESO GR. WEIGHT GR.	VOL. IN M ³ VOL. IN M ³	PEZZI IMBALLO OUTER BOX	FASCIA PREZZO PRICE RANGE
CUR.1 Ottone / Brass				B24
CUR.1.NI Nichel / Nickel	200	0,02	1	B24
CUR.1.RS Rustic Silver™				B32
CUR.2 Ottone / Brass				B21
CUR.2.NI Nichel / Nickel	135	0,02	1	B21
CUR.2.RS Rustic Silver™				B26
CUR.3 Ottone / Brass				B17
CUR.3.NI Nichel / Nickel	68	0,02	1	B17
CUR.3.RS Rustic Silver™				B23

Per un corretto montaggio

For correct assembling

Per comporre un impianto esterno è indispensabile, per prima cosa, segnare la traccia che si desidera seguire. Si posizionano quindi le scatole di derivazione e le lampade o le appliques più appropriate al tipo di impianto scelto. Una volta fissati questi articoli si procederà alla posa di tutti gli altri elementi che compongono il vostro impianto. Nel caso utilizzate canalette diverse da quelle di nostra produzione vi raccomandiamo di attenervi alle misure riportate nel catalogo.

Per collegare tra loro le canalette si utilizzano gli articoli RAC (raccordo per canaletta), VOL (raccordo volante) o SUP (supporto a muro) assicurandovi che questi articoli corrispondano al diametro della canaletta scelta. Nel caso voleste fissare al muro una serie di raccordi, vi ricordiamo che ad un raccordo fisso (RAC o SUP) è sufficiente far seguire un raccordo volante (VOL).

Sottoponiamo alcuni esempi esplicativi.

To compose an external system firstly mark the layout to be followed. Then position the DISTRIBUTION BOXES (A) and the LAMPS and WALL LAMPS (F) most appropriate to the type of system chosen (to fix the latter articles see example n.2 described below). Once these articles are fixed proceed with installing all the other elements making up your system. If different ducting to our production is used, make sure to follow the dimensions given in the catalogue. To connect the ducting together use the articles RAC (B), SUP (C) or VOL (D), making sure that these articles match the diameter of the ducting chosen. To fix a series of connectors to the wall, remember that it is sufficient to follow one FLYING CONNECTOR (VOL) with a FIXED CONNECTOR (RAC OR SUP).

A few explanatory examples are given below.

Realizzare una curva To make a bend

Mediante l'articolo RAC, precedentemente fissato al muro **B**, si collega la canaletta lineare (LIN 1-2-3) all'articolo CUR 1-2-3 prescelto **E**.
Si prosegue quindi l'impianto dopo la curva con un articolo VOL 1-2-3 **D**.
È indispensabile utilizzare gli articoli sopra elencati rispettando la sequenza da noi indicata in quanto l'articolo VOL posto dopo la curva essendo volante e non fisso, permette di facilitare l'inserimento della canaletta successiva.

By means of article RAC, previously fixed to the wall (**B**), connect the straight ducting (LIN 1-2-3) to chosen article CUR 1-2-3 (**E**).
Then continue the system after the bend with article VOL 1-2-3 (**D**).
It is essential to use the above mentioned articles in the order given by us because in being flying and not fixed article VOL placed after the bend, facilitates insertion of the next ducting.

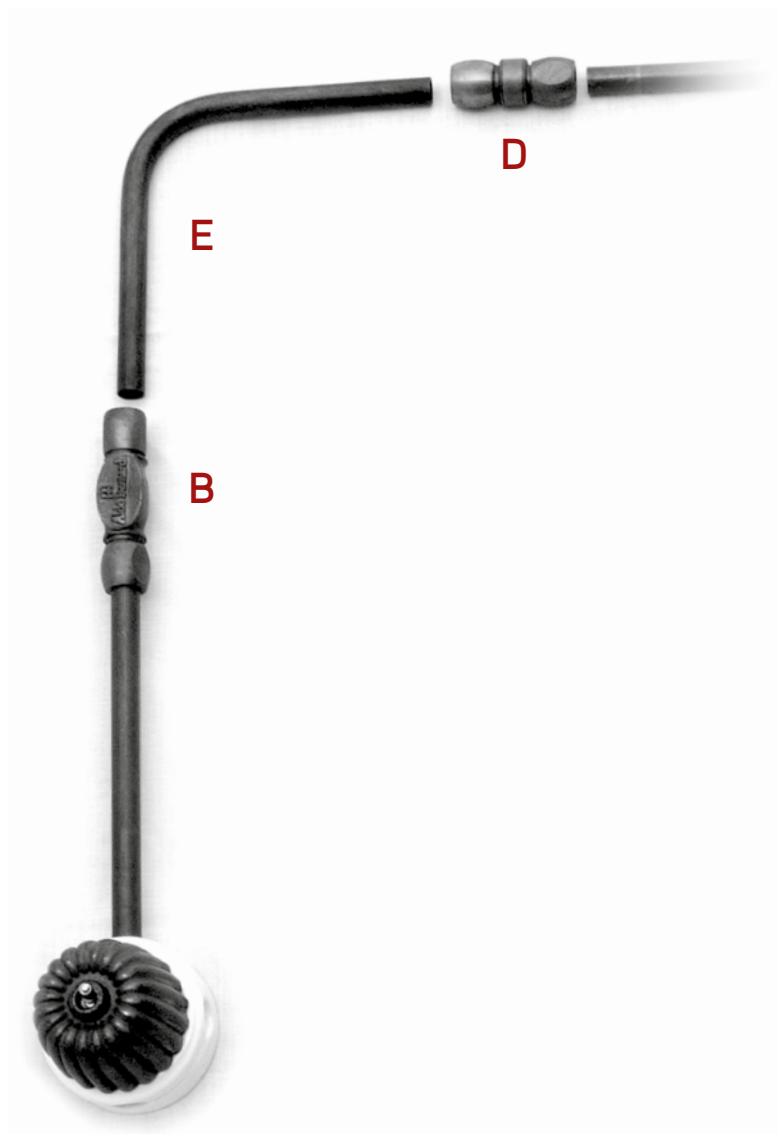

Installazione di una sospensione o di una applique. Installation of a ceiling lamp or wall lamp.

Per questi due articoli è necessario scegliere canalette da \varnothing 10 mm o da \varnothing 16 mm. È indispensabile calcolare precedentemente il cavo totale necessario al collegamento tra il corpo luminoso e gli articoli ad esso collegati, quali ad esempio una scatola di derivazione **A**, un interruttore **I** o un successivo corpo luminoso. Posizionare la staffa a muro avendo l'accortezza di porre le barre filettate per il fissaggio a 45° rispetto all'asse della canaletta **G**. Collegare i cavi di conduzione elettrica **H** al morsetto posto all'interno della base lampada o dell'applique **M**, rispettando i simboli L (LINEA) ed N (NEUTRO). A questo punto si posizionerà la lampada o l'applique facendo uscire i cavi di alimentazione dai fori della base **L** ed inserendoli dentro la canaletta.

For these two articles it is necessary to choose ducting of 10 mm \varnothing or 16 mm \varnothing . It is essential to previously calculate the total length of cable required for connection between the illuminating body and the articles connected to it, such as for example a DISTRIBUTION BOX (A), a SWITCH (I) or another illuminating body. Position the bracket on the wall taking care to place the threaded bars for fixing at 45° to the axis of the DUCTING (G). Connect the electrical WIRES (H) to the terminal located inside the base of the lamp or of the WALL LAMP (M), following the symbols L (LINE) and N (NEUTRAL). At this point position the lamp or the wall lamp bringing the feed cables out of the holes of the BASE (L) and inserting them inside the ducting.

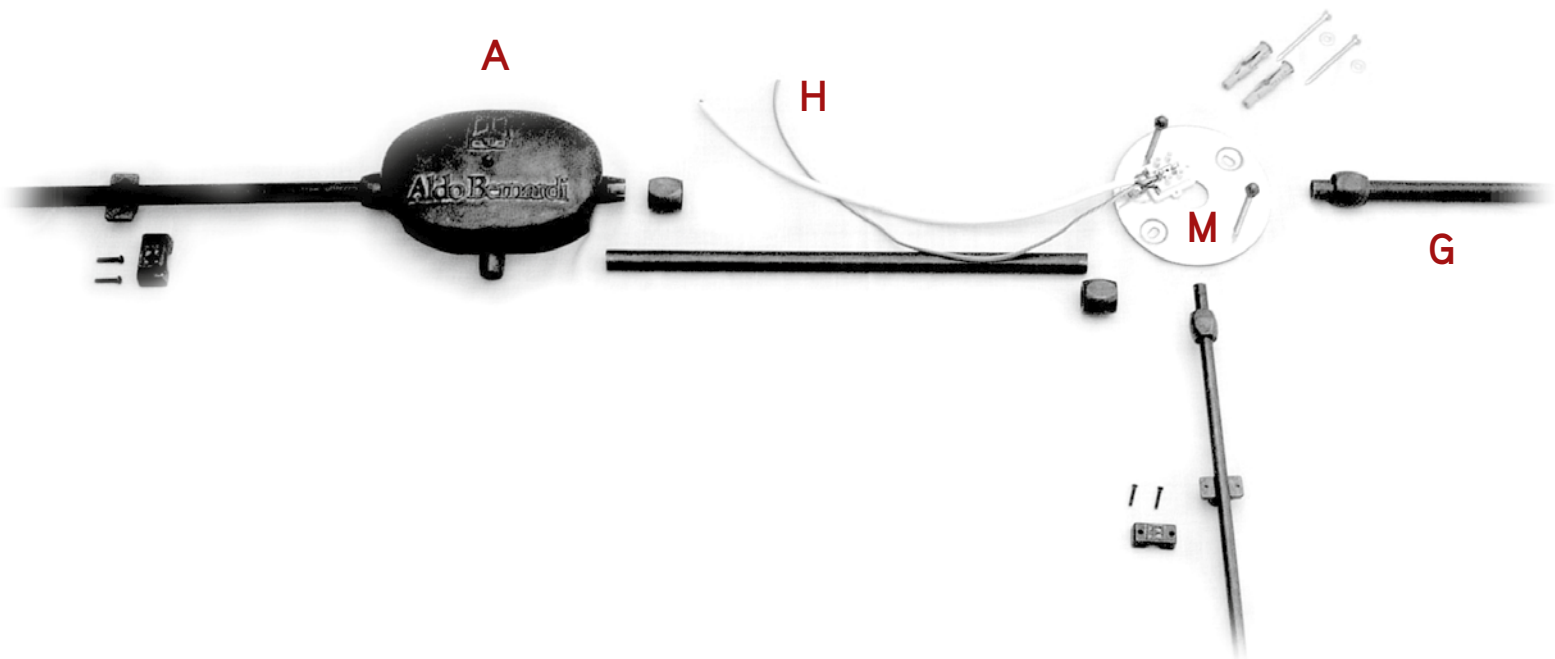

Calcolare l'esatta misura di una canaletta lineare (lin 1-2-3) da un corpo all'altro. Calculate the exact distance of a straight ducting (lin 1-2-3) from one body to another.

Si misura la lunghezza tra le estremità dei due corpi (per esempio da CIL a CIL **O**, o da RAC a interruttore **R**, etc...) aggiungendo a questo valore 50 mm se si utilizza l'articolo LIN 3 e 60 mm se si utilizzano gli articoli LIN 1 o LIN 2.

Quindi far entrare la canaletta scelta dalla parte del CIL **L** sino a far combaciare l'estremità opposta della canaletta **P** con l'altro raccordo **Q**. Inserire la canaletta avendo l'accortezza di bilanciare l'eccedenza. Fissare quindi la canaletta ai vari raccordi utilizzando una chiave fissa. Per rendere l'impianto a tenuta stagna si raccomanda l'uso del teflon per isolare.

Measure the length between the ends of the two bodies (for example from cil to CIL (O), or from RAC to SWITCH (R), etc.) adding 50 mm to this value if using article LIN 3 and 60 mm if using articles LIN 1 or LIN 2.

Then bring the chosen ducting from the part of the CIL (L) until matching the opposite end of DUCTING (P) with the other CONNECTOR (Q).

Then insert the ducting taking care to balance the excess then fixing the ducting to the various connectors using a fixed spanner. To make the system tight, use teflon to insulate.

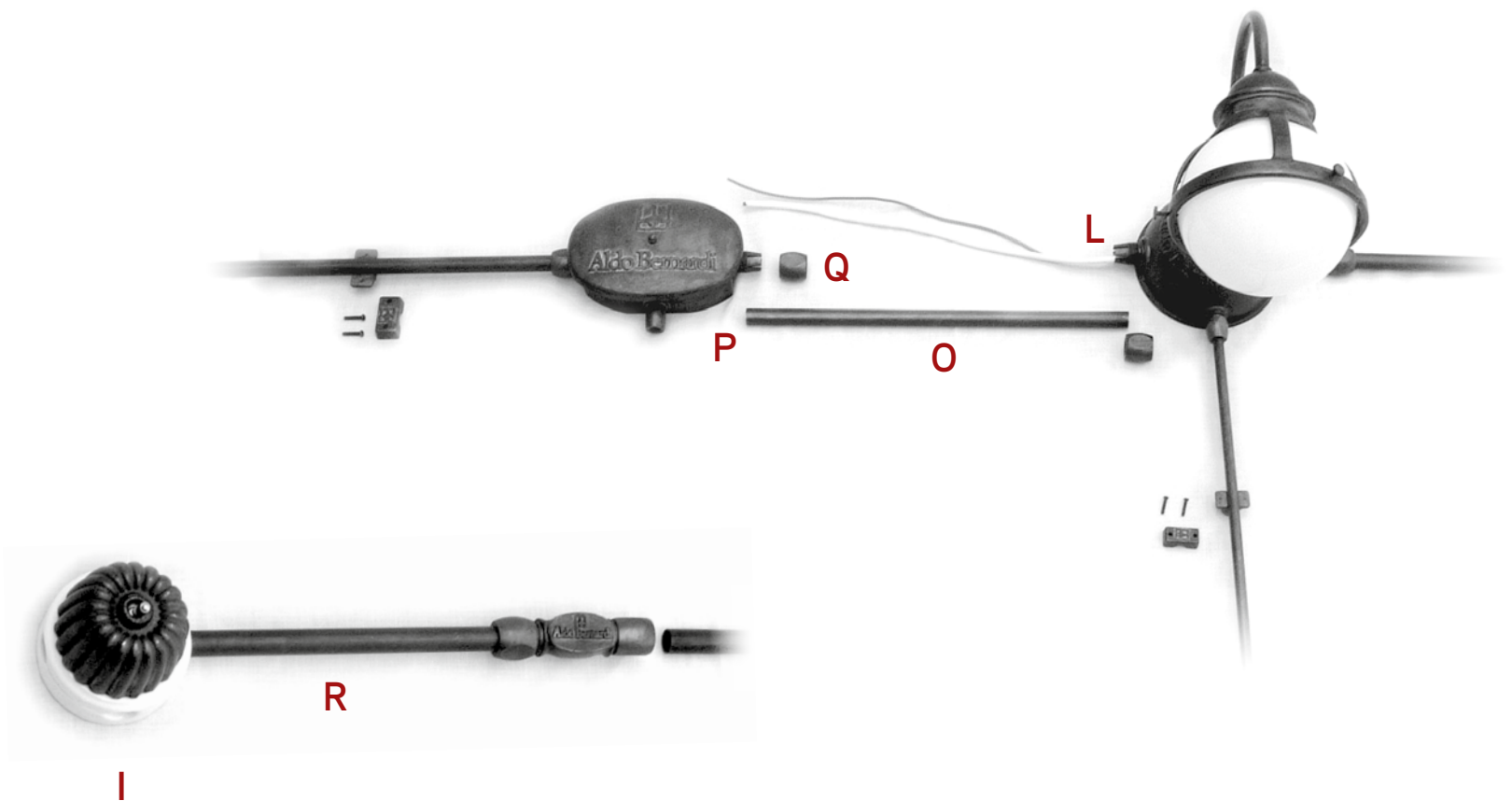

CIVETTA

“Civetta”, un’originale linea di sospensioni e spot a parete o a plafone che si presta a molteplici applicazioni. Arriva ovunque e, se lo desideri, permette di illuminare anche le zone più buie dei propri pensieri! Sia il sistema “Multi Ap” che quello “SPR” sono belli da vedere, valorizzano la parete dove sono installati e soprattutto, possono risolvere problematiche dovute a carenza di punti luce.

“Civetta” is an original line of pendants, spot and ceiling lamps, adjustable to many applications. It gets anywhere and, if desired, allow to bright even the darkest areas of your thoughts! Both “Multi Ap” system than the “SPR” one are beautiful to see, add value to the wall where they are installed and, above all, can solve problems due to shortage of light points.



Le sospensioni pensili Civetta e l'Impianto a vista illuminano alla grande il bar del "7 Risto" (Canada).
Aldo Bernardi's Civetta pendants and l'Impianto system look mighty the bar at "7 Risto" (Canada).



LINEA

Civetta

sistema "Multi-Ap"
"Multi-Ap" spot system

Serie di sospensioni o faretti pensili, in ottone anticato, disponibili anche nella versione per lampada PAR20, non inclusa nell'articolo. Fulcro di questo sistema è il "multi ap", sostanzialmente un connettore per molteplici applicazioni che permette di collegare da uno a tre punti luce.

Gli articoli, vanno collegati a tubi di 16 mm. di diametro e a eventuali altri elementi, da ordinare a parte, necessari alla realizzazione di questo tipo di impianto.

Series of pendants and spotlights hanging, in aged brass finish available also for PAR20 lamp, not included in the article. The fulcrum of this system is the "multi ap", substantially a connector for multiple applications that allows to connect from one to three light points.

The articles must be connected to 16 mm diam. section conduits and to the accessories required to the realization of this type of system, to be order separately.



Art. 11.416/PAR20

Art. LIN.2



Sistema multi-ap (modello brevettato)
Multi-ap system (patented model)

Art. 11.416/P22
Art. LIN.2



Art. 11.416/P22/PAR20
Art. LIN.2



42

Art. 11.422/PAR20
Art. LIN.2

Supporto per art. LIN.2
LIN.2 support



Art. 11.522/PAR20
Art. LIN.2



Impianto "a vista" a Chicago, in Merchandise Mart.

Wiring surface mounted system on the 18th floor of the world famous Chicago's Merchandise Mart.



Art. 11.416/PAR20

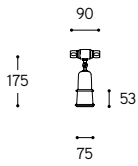

Art. 11.422/PAR20

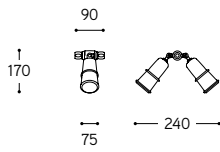

Art. 11.522/PAR20

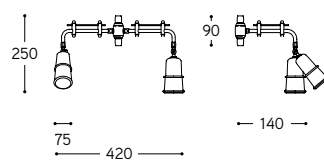

.../P22/PAR20

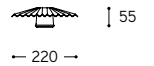

.../P26/PAR20

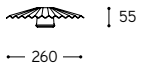

Art. 11.416/P22

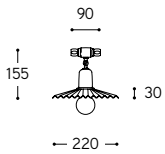

Art. 11.416/P26

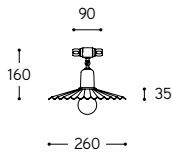

Art. 11.416/P29

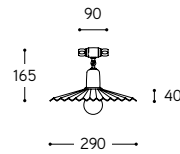

Art. LIN.2 Support



.../P29/PAR20

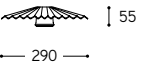

ARTICOLO ITEM	DESCRIZIONE DESCRIPTION	ATTACCO SOCKET	POTENZA POWER	PESO GR. WEIGHT GR.	VOL. IN M ³ VOL. IN M ³	PEZZI IMBALLO OUTER BOX	FASCIA PREZZO PRICE RANGE
Faretto pendente senza piatto / Short pendant spot without shade							
11.416/PAR20	Faretto con portalampada PAR20 / Spot with PAR20 lampholder	E27	50W	1.200	0,01	1	B65
11.422/PAR20	Doppio faretto con portalampade PAR20 / Double-spot with PAR20 lampholders	E27	50W	750	0,02	1	B87
11.522/PAR20	Doppio faretto con portalampade PAR20 / Double-spot with PAR20 lampholders	E27	50W	1.020	0,06	1	B92
Faretto pendente con piatto / Short pendant spot with shade							
11.416/P22	Faretto / Spot	E27	70W *	1.480	0,02	1	B71
11.416/P22/PAR20	Faretto con portalampada PAR20 / Spot with PAR20 lampholder	E27	50W	1.540	0,02	1	B74
11.416/P26	Faretto / Spot	E27	70W *	1.600	0,02	1	B71
11.416/P26/PAR20	Faretto con portalampada PAR20 / Spot with PAR20 lampholder	E27	50W	1.660	0,02	1	B74
11.416/P29	Faretto / Spot	E27	70W *	1.680	0,02	1	B71
11.416/P29/PAR20	Faretto con portalampada PAR20 / Spot with PAR20 lampholder	E27	50W	1.740	0,02	1	B74
LIN.2 SUPPORT	Supporto per Art. LIN.2 / LIN.2 Support			144	0,0002	1	B34



Per Art. LIN.2 Support misure a richiesta / For Article LIN.2 Support on request different measures

LINEA

Civetta

sistema "Multi-Ap" "Multi-Ap" spot system

Serie sospensioni in ottone anticato, disponibili anche nella versione per lampada PAR20, non inclusa nell'articolo. Il riflettore pieghettato è disponibile in tre misure, da 220 mm, da 260 mm e da 290 mm di diametro.

L'articolo, adatto all' "Impianto a vista", va collegato a tubi di 16 mm. di diametro e a tutti quei componenti, da ordinare a parte, necessari alla realizzazione di questo tipo di impianto.

Series of pendants, in aged brass finish, available for PAR20 bulb version too, not included. Pleated shade is available in 220 mm diam, 260 mm diam. and 260 mm diam. section. The article, suitable for the "Surface mounted wiring system", must be connected to 16 mm diam. section conduits and to the accessories required to the realization of this type of system.



Art. 11.516/P26
Art. LIN.2

Art. 11.516/P22

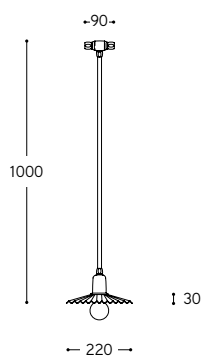

Art. 11.516/P26

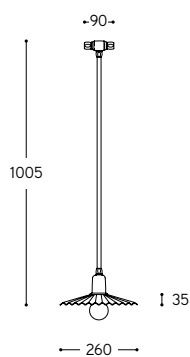

Art. 11.516/P29

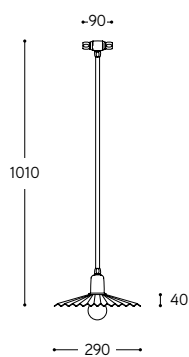

.../P22/PAR20

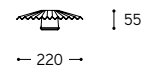

.../P26/PAR20

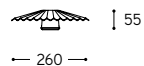

.../P29/PAR20

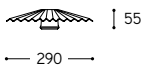

ARTICOLO ITEM	DESCRIZIONE DESCRIPTION	ATTACCO SOCKET	POTENZA POWER	PESO GR. WEIGHT GR.	VOL. IN M ³ VOL. IN M ³	PEZZI IMBALLO OUTER BOX	FASCIA PREZZO PRICE RANGE
11.516/P22	Sospensione / Pendant	E27	70W *	2.410	0,09	1	B73
11.516/P22/PAR20	Sospensione con portalampada PAR20 / Pendant with PAR20 lampholder	E27	50W	2.480	0,09	1	B76
11.516/P26	Sospensione / Pendant	E27	70W *	2.540	0,09	1	B73
11.516/P26/PAR20	Sospensione con portalampada PAR20 / Pendant with PAR20 lampholder	E27	50W	2.610	0,09	1	B76
11.516/P29	Sospensione / Pendant	E27	70W *	2.610	0,09	1	B73
11.516/P29/PAR20	Sospensione con portalampada PAR20 / Pendant with PAR20 lampholder	E27	50W	2.680	0,09	1	B76

CE ⊕ IP20

LINEA

Civetta

sistema SPR SPR system

Integrazione del sistema « Multi Ap » è il sistema SPR, indicato quando i punti luce da collegare tramite un impianto a vista superano le 3 unità. Gli articoli, vanno collegati a tubi di 16 mm di diametro. La sua versatilità, combinata a tutti gli accessori di nostra produzione, rende possibili soluzioni adatte a svariate esigenze in quanto riduce il quantitativo di cavi passanti dentro alle canalette.

SPR system is an integration of 'multi ap " sypsem, indicated when the lights to connect through a surface wiring system exceed 3 units. The articles must be connected to tubes of 16 mm diam. section. Its versatility, combined with all the accessories of our production, makes possible solutions for different needs.



Art. SPR/4
Art. 11.516/PAR 20/SC
Art. LIN2







- 2) Art. SPR/180
- 1) Art. 11.416/PAR20/SC
- 1) Art. 11.422/PAR20/SC
- 1) Art. CUR2
- 1) Art. LIN2



Art. SC/SUPPORTO
Art. SPR/180
Art. LIN2



Art. SC/ROSONE
Art. SPR/180
Art. LIN2

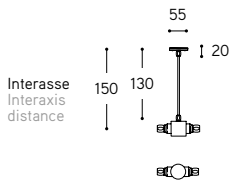

Art. SC/SUPPORTO

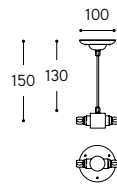

Art. SC/ROSONE

Art. SPR/BOX



Art. SPR/1

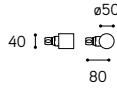

Art. SPR/90

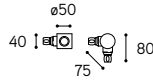

Art. SPR/180

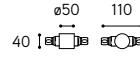

Art. SPR/3

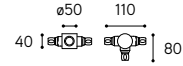

Art. SPR/4

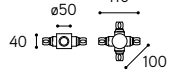

Art. 11.416/P22/SC

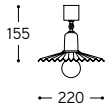

Art. 11.416/P22/PAR20/SC

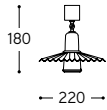

Art. 11.416/P26/SC

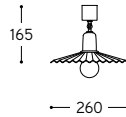

Art. 11.416/P26/PAR20/SC

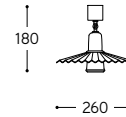

Art. 11.416/P29/SC

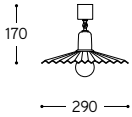

Art. 11.416/P29/PAR20/SC

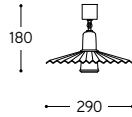

Art. 11.416/PAR20/SC

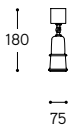

Art. 11.422/PAR20/SC

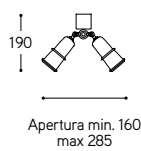

Art. 11.522/PAR20/SC

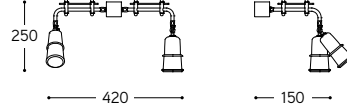

Art. 11.516/PAR20/SC

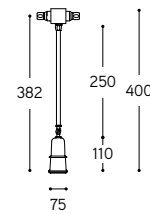

ARTICOLO ITEM	DESCRIZIONE DESCRIPTION	PESO GR. WEIGHT GR.	VOL. IN M ³ VOL. IN M ³	FASCIA PREZZO PRICE RANGE
SPR/BOX	Scatola SPR in ottone anticato senza uscite SPR box in aged brass without output	340	0,001	B32
SPR/1	Scatola SPR in ottone anticato, comprensiva di raccordo cil 16, ad un'uscita SPR box in aged brass, cil 16 connection included, with single output	320	0,001	B37
SPR/90	Scatola SPR in ottone anticato, comprensiva di raccordo cil 16, a due uscite a 90° SPR box in aged brass, cil 16 connection included, with two 90° outputs	400	0,001	B42
SPR/180	Scatola SPR in ottone anticato, comprensiva di raccordo cil 16, a due uscite a 180° SPR box in aged brass, cil 16 connection included, with two 180° outputs	400	0,001	B42
SPR/3	Scatola SPR in ottone anticato, comprensiva di raccordo cil 16, a tre uscite SPR box in aged brass, cil 16 connection included, with three outputs	480	0,001	B49
SPR/4	Scatola SPR in ottone anticato, comprensiva di raccordo cil 16, a quattro uscite SPR box in aged brass, cil 16 connection included, with four outputs	580	0,001	B56
SC/ROSONE	Supporto rosone SPR in ottone anticato per entrata cavo, interasse 150 mm* SPR ceiling rose in aged brass for lead entry interawrd, interaxis distance 150 mm	480	0,002	B37
SC/SUPPORTO	Elemento distanziale di supporto SPR in ottone anticato, interasse 150 mm* Spacer stub element SPR in aged brass, interaxis distance 150 mm	220	0,002	B29

* A richiesta sono disponibili misure diverse
Upon request can be available different sizes

Art. 11.516/P22/SC

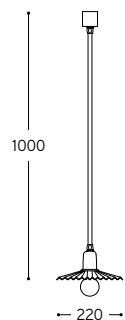

Art. 11.516/P22/PAR20/SC

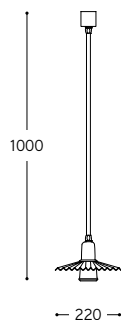

Art. 11.516/P26/SC

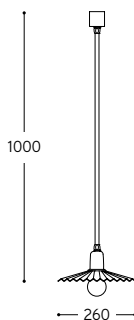

Art. 11.516/P26/PAR20/SC

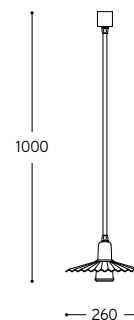

Art. 11.516/P29/SC

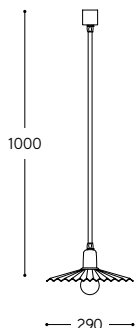

Art. 11.516/P29/PAR20/SC

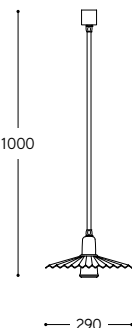

Le scatole del sistema SPR vanno utilizzate separatamente o con le seguenti lampade della linea Civetta.
 SPR system boxes can be used either separately or with the following lamps of the Civetta collection.

ARTICOLO ITEM	DESCRIZIONE DESCRIPTION	ATTACCO SOCKET	POTENZA POWER	PESO GR. WEIGHT GR.	VOL. IN M ³ VOL. IN M ³	FASCIA PREZZO PRICE RANGE
11.416/PAR20/SC	Faretto con snodo per sistema SPR, per PAR20 SPR system adjustable spot for PAR20 bulb	E27	50W	740	0,01	B48
11.422/PAR20/SC	Doppio faretto con snodo per sistema SPR per PAR20 Double SPR system adjustable spot for PAR20 bulb	E27	2x50W	1280	0,02	B77
11.522/PAR20/SC	Doppio faretto con snodo per sistema SPR per PAR20 Double SPR system adjustable spot for PAR20 bulb	E27	2x50W	2400	0,09	B88
11.516/PAR20/SC	Faretto fisso per sistema SPR, per PAR20, altezza totale 400 mm SPR system spot for PAR20 bulb total height 400 mm	E27	50W	1240	0,03	B51
11.416/P22/SC	Faretto con snodo per sistema SPR con piatto Ø 220 mm SPR system adjustable spot with Ø 220 mm shade	E27	70W*	1220	0,02	B59
11.416/P22/PAR20/SC	Faretto con snodo per sistema SPR per PAR20 con piatto Ø 220 mm SPR system adjustable spot for PAR20 bulb with Ø 220 mm shade	E27	50W	1280	0,02	B63
11.416/P26/SC	Faretto con snodo per sistema SPR con piatto Ø 260 mm SPR system adjustable spot with Ø 260 mm shade	E27	70W*	1360	0,02	B59
11.416/P26/PAR20/SC	Faretto con snodo per sistema SPR per PAR20 con piatto Ø 260 mm SPR system adjustable spot for PAR20 bulb with Ø 260 mm shade	E27	50W	1420	0,02	B63
11.416/P29/SC	Faretto con snodo per sistema SPR con piatto Ø 290 mm SPR system adjustable spot with Ø 290 mm shade	E27	70W*	1460	0,02	B59
11.416/P29/PAR20/SC	Faretto con snodo per sistema SPR per PAR20 con piatto Ø 290 mm SPR system adjustable spot for PAR20 bulb with Ø 290 mm shade	E27	50W	1520	0,02	B63
11.516/P22/SC	Sospensione per sistema SPR con piatto Ø 220 mm SPR system pendant with Ø 220 mm shade	E27	70W*	2620	0,09	B61
11.516/P22/PAR20/SC	Sospensione per sistema SPR per PAR20 con piatto Ø 220 mm SPR system pendant for PAR20 bulb with Ø 220 mm shade	E27	50W	2680	0,09	B65
11.516/P26/SC	Sospensione per sistema SPR con piatto Ø 260 mm SPR system pendant with Ø 260 mm shade	E27	70W*	2740	0,09	B61
11.516/P26/PAR20/SC	Sospensione per sistema SPR per PAR20 con piatto Ø 260 mm SPR system pendant for PAR20 bulb with Ø 260 mm shade	E27	50W	2800	0,09	B65
11.516/P29/SC	Sospensione per sistema SPR con piatto Ø 290 mm SPR system pendant with Ø 290 mm shade	E27	70W*	2840	0,09	B61
11.516/P29/PAR20/SC	Sospensione per sistema SPR per PAR20 con piatto Ø 290 mm SPR system pendant for PAR20 bulb with Ø 290 mm shade	E27	50W	2900	0,09	B65

LINEA MODULARE

Questa linea raccoglie 4 diversi sistemi di impianto elettrico a vista, realizzato con spot e canaline. Le componenti di questi sistemi permettono di realizzare forme grafiche differenti, quali quadri, rombi, moduli ondulati.

This line contains four different systems of electrical system to view, made spot and conduits. The elements of these systems allow to create different graphical shapes, such as square, rhombus, wavy forms.

LINEA

Linea Modulare

sistema "i Quadri"

"i Quadri" system

Composizione formata da spot, eventuale scatola di connessione e canaline da 16 mm di diametro. Lo spot, comprensivo di raccordo, è formato da una base in ottone anticato o in nichel satinato e da un modulo portalamпада in ceramica, con finitura bianco lucido o nero matt. Può essere utilizzato come spot singolo o con varie uscite, tutte ad angolo retto. Le canaline da abbinare, sono disponibili nelle stesse finiture dello spot. Accessorio interessante è la scatola di connessione che, come nella foto del catalogo, può venire utilizzata per la realizzazione di una striscia di quadri.

The composition includes spot, eventual connection box and conduits 16 mm diam. The spot consists of a base in antique brass or satin nickel and from a ceramic lamp holder, glossy white or matt black finishing. It can be used as a single spot or with more right angle outputs. Conduits are available in the same finishes of the spot. The connection box, which may be used as in the photo presented of the catalog, can be used to realize a strip of square.











Art. SQ/.../...

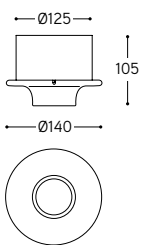

Art. SQ1/.../...

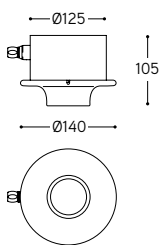

Art. SQ90/.../...

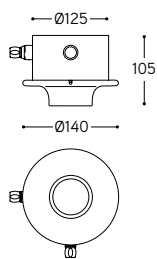

Art. SQ180/.../...

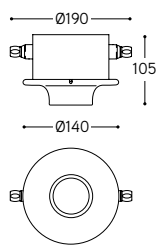

Art. SQ3/.../...

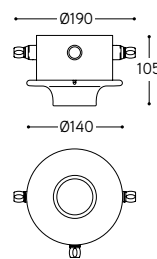

Art. SQ4/.../...

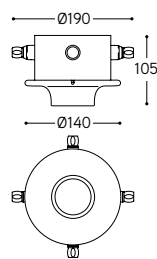

Art. SQDER90/...

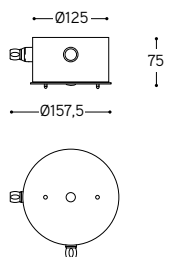

Art. SQDER4/...

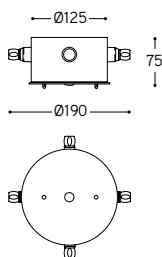

Art. LIN2/.../26

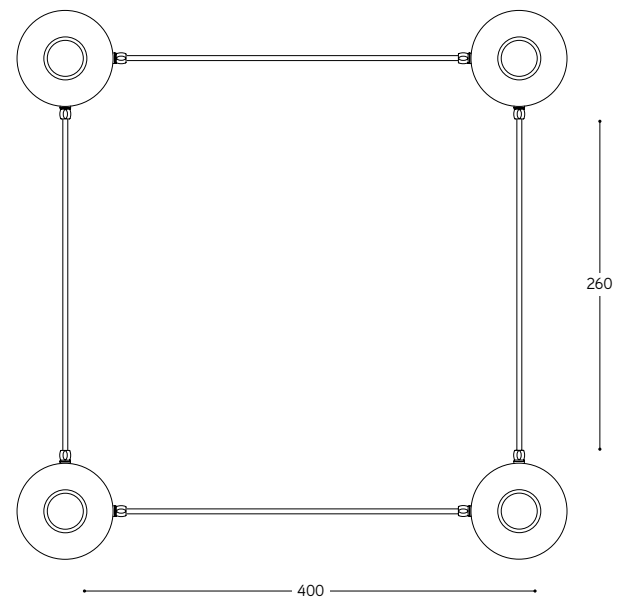
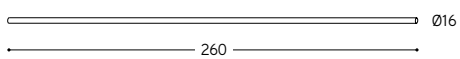

ARTICOLO ITEM	DESCRIZIONE DESCRIPTION	ATTACCO SOCKET	POTENZA POWER	PESO GR. WEIGHT GR.	VOL. IN M ³ VOL. IN M ³	FASCIA PREZZO PRICE RANGE
SQ/O/...	Spot con base in ottone anticato senza uscite e modulo portalampada in ceramica Spot with aged brass base and ceramic lamp holder module	E27	42W	1660	0,01	B45
SQ/NS/...	Spot con base in nichel satinato senza uscite e modulo portalampada in ceramica Spot with satin nickel base and ceramic lamp holder module	E27	42W	1660	0,01	B46
SQ1/O/...	Spot con base in ottone anticato ad una uscita, comprensivo di raccordo cil 16 mm, e modulo portalampada in ceramica / Spot with aged brass base with single output, cil 16 mm connection included, and ceramic lamp holder module	E27	42W	1660	0,01	B50
SQ1/NS/...	Spot con base in nichel satinato ad una uscita, comprensivo di raccordo cil 16 mm, e modulo portalampada in ceramica / Spot with satin nickel base with single output, cil 16 mm connection included, and ceramic lamp holder module	E27	42W	1660	0,01	B51
SQ90/O/...	Spot con base in ottone anticato a due uscite a 90°, comprensivo di raccordi cil 16 mm, e modulo portalampada in ceramica / Spot with aged brass base with two 90° outputs, cil 16 mm connections included, and ceramic lamp holder module	E27	42W	1660	0,01	B55
SQ90/NS/...	Spot con base in nichel satinato a due uscite a 90°, comprensivo di raccordi cil 16 mm, e modulo portalampada in ceramica / Spot with satin nickel base with two 90° outputs, cil 16 mm connections included, and ceramic lamp holder module	E27	42W	1660	0,01	B56
SQ180/O/...	Spot con base in ottone anticato a due uscite a 180°, comprensivo di raccordi cil 16 mm, e modulo portalampada in ceramica / Spot with aged brass base with two 180° outputs, cil 16 mm connections included, and ceramic lamp holder module	E27	42W	1660	0,01	B55
SQ180/NS/...	Spot con base in nichel satinato a due uscite a 180°, comprensivo di raccordi cil 16 mm, e modulo portalampada in ceramica / Spot with satin nickel base with two 180° outputs, cil 16 mm connections included, and ceramic lamp holder module	E27	42W	1660	0,01	B56
SQ3/O/...	Spot con base in ottone anticato a tre uscite, comprensivo di raccordi cil 16 mm, e modulo portalampada in ceramica / Spot with aged brass base with three outputs, cil 16 mm connections included, and ceramic lamp holder module	E27	42W	1660	0,01	B60
SQ3/NS/...	Spot con base in nichel satinato a tre uscite, comprensivo di raccordi cil 16 mm, e modulo portalampada in ceramica / Spot with satin nickel base with three outputs, cil 16 mm connections included, and ceramic lamp holder module	E27	42W	1660	0,01	B62
SQ4/O/...	Spot con base in ottone anticato a quattro uscite, comprensivo di raccordi cil 16 mm, e modulo portalampada in ceramica / Spot with aged brass base with four outputs, cil 16 mm connections included, and ceramic lamp holder module	E27	42W	1660	0,01	B62
SQ4/NS/...	Spot con base in nichel satinato a quattro uscite, comprensivo di raccordi cil 16 mm, e modulo portalampada in ceramica / Spot with satin nickel base with four outputs, cil 16 mm connections included, and ceramic lamp holder module	E27	42W	1660	0,01	B64
SQDER90/O	Scatola di connessione in ottone anticato a due uscite a 90° comprensiva di raccordi cil 16 mm Connection box in aged brass, with two 90° outputs, cil 16 mm connection included			1580	0,01	B41
SQDER90/NS	Scatola di connessione in nichel satinato a due uscite a 90° comprensiva di raccordi cil 16 mm Connection box in satin nickel, with two 90° outputs, cil 16 mm connection included			1580	0,01	B42
SQDER4/O	Scatola di connessione in ottone anticato a quattro uscite comprensiva di raccordi cil 16 mm Connection box in aged brass, with four outputs, cil 16 mm connection included			1580	0,01	B47
SQDER4/NS	Scatola di connessione in nichel satinato a quattro uscite comprensiva di raccordi cil 16 mm Connection box in satin nickel, with four outputs, cil 16 mm connection included			1580	0,01	B49
LIN2/O/26	Canalina in ottone anticato, 16 mm diam. lunghezza 260 mm, interasse 400 mm Aged brass conduit 16 mm diam. length 260 mm, interaxis distance 400 mm *			460	0,01	B4
LIN2/NS/26	Canalina in nichel satinato, 16 mm. mm. diam. lunghezza 260 mm, interasse 400 mm Satin nickel conduit 16 mm diam. length 260 mm, interaxis distance 400 mm *			460	0,01	B5

CE ⊕ IP20  

Colore modulo portalampada in ceramica
Ceramic lamp holder color

BL = Bianco lucido / Glossy white

NM = Nero matt / Matte Black

* A richiesta sono disponibili misure diverse
Upon request can be available different sizes

LINEA

Linea Modulare

sistema "i Rombi"

"i Rombi" system

Composizione formata da spot e canaline da 16 mm. di diam.

Lo spot, comprensivo di raccordo, è formato da una base in ottone anticato o in nichel satinato e da un modulo portalampada in ceramica, con finitura bianco lucido o nero matt. Può essere utilizzato come spot singolo o con varie uscite che permettono la realizzazione di un rombo. Le canaline da abbinare, sono disponibili nelle stesse finiture dello spot.

The composition includes spot and conduits 16 mm. diam.

The spot consists of a base in antique brass or satin nickel and from a ceramic lamp holder, glossy white or matt black finishing. It can be used as a single spot or with more outputs that allow the realization of a rhombus.

Conduits are available in the same finishes of the spot.







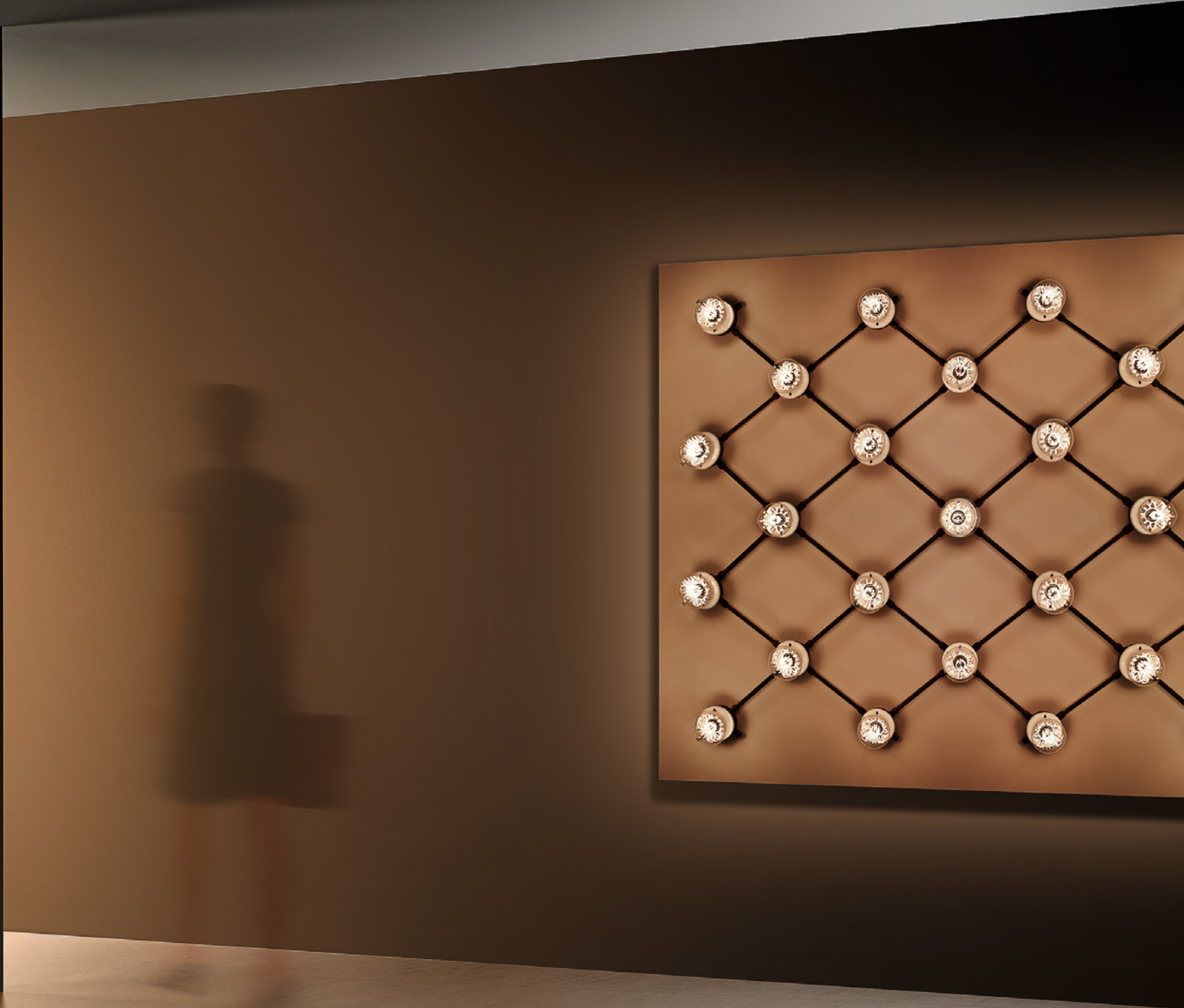







Art. SR/.../...

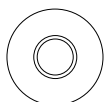
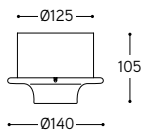

Art. SR1/.../...

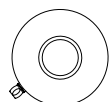
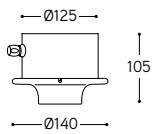

Art. SR75/.../...

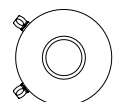
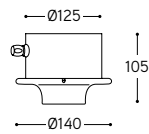

Art. SR105/.../...

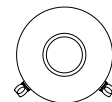
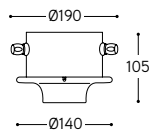

Art. SR180/.../...

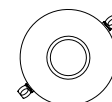
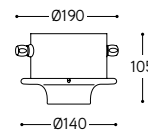

Art. SR3A/.../...

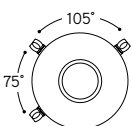
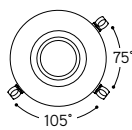
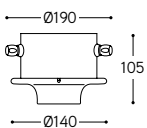

Art. SR3B/.../...

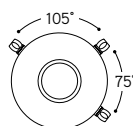
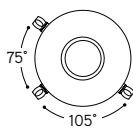
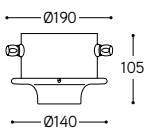

Art. SR4/.../...

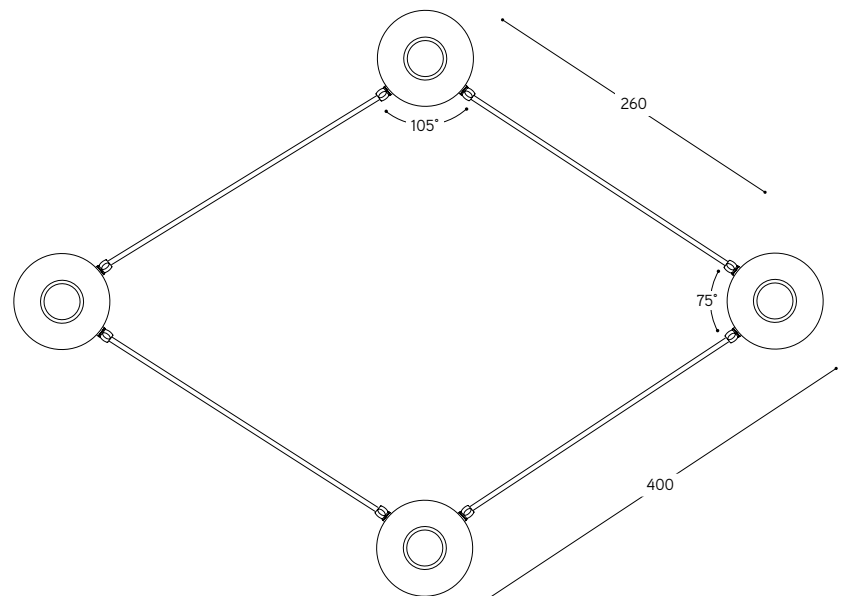
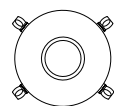
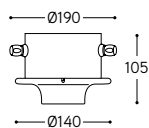

Art. LIN2/.../26

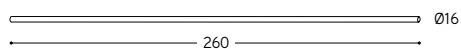

ARTICOLO ITEM	DESCRIZIONE DESCRIPTION	ATTACCO SOCKET	POTENZA POWER	PESO GR. WEIGHT GR.	VOL. IN M ³ VOL. IN M ³	FASCIA PREZZO PRICE RANGE
SR/O/...	Spot con base in ottone anticato senza uscite e modulo portalamпада in ceramica Spot with aged brass base and ceramic lamp holder module	E27	42W	1660	0,01	B45
SR/NS/...	Spot con base in nichel satinato senza uscite e modulo portalamпада in ceramica Spot with satin nickel base and ceramic lamp holder module	E27	42W	1660	0,01	B46
SR1/O/...	Spot con base in ottone anticato ad una uscita, comprensivo di raccordo cil 16 mm, e modulo portalamпада in ceramica / Spot with aged brass base with single output, cil 16 mm connection included, and ceramic lamp holder module	E27	42W	1660	0,01	B50
SR1/NS/...	Spot con base in nichel satinato ad una uscita, comprensivo di raccordo cil 16 mm, e modulo portalamпада in ceramica / Spot with satin nickel base with single output, cil 16 mm connection included, and ceramic lamp holder module	E27	42W	1660	0,01	B51
SR75/O/...	Spot con base in ottone anticato a due uscite a 75°, comprensivo di raccordi cil 16 mm, e modulo portalamпада in ceramica / Spot with aged brass base with two 75° outputs, cil 16 mm connections included, and ceramic lamp holder module	E27	42W	1660	0,01	B55
SR75/NS/...	Spot con base in nichel satinato a due uscite a 75°, comprensivo di raccordi cil 16 mm, e modulo portalamпада in ceramica / Spot with satin nickel base with two 75° outputs, cil 16 mm connections included, and ceramic lamp holder module	E27	42W	1660	0,01	B56
SR105/O/...	Spot con base in ottone anticato a due uscite a 105°, comprensivo di raccordi cil 16 mm, e modulo portalamпада in ceramica / Spot with aged brass base with two 105° outputs, cil 16 mm connections included, and ceramic lamp holder module	E27	42W	1660	0,01	B55
SR105/NS/...	Spot con base in nichel satinato a due uscite a 105°, comprensivo di raccordi cil 16 mm, e modulo portalamпада in ceramica / Spot with satin nickel base with two 105° outputs, cil 16 mm connections included, and ceramic lamp holder module	E27	42W	1660	0,01	B56
SR180/O/...	Spot con base in ottone anticato a due uscite a 180°, comprensivo di raccordi cil 16 mm, e modulo portalamпада in ceramica / Spot with aged brass base with two 180° outputs, cil 16 mm connections included, and ceramic lamp holder module	E27	42W	1660	0,01	B55
SR180/NS/...	Spot con base in nichel satinato a due uscite a 180°, comprensivo di raccordi cil 16 mm, e modulo portalamпада in ceramica / Spot with satin nickel base with two 180° outputs, cil 16 mm connections included, and ceramic lamp holder module	E27	42W	1660	0,01	B56
SR3A/O/...	Spot con base in ottone anticato a tre uscite, comprensivo di raccordi cil 16 mm, e modulo portalamпада in ceramica / Spot with aged brass base with three outputs, cil 16 mm connections included, and ceramic lamp holder module	E27	42W	1660	0,01	B60
SR3A/NS/...	Spot con base in nichel satinato a tre uscite, comprensivo di raccordi cil 16 mm, e modulo portalamпада in ceramica / Spot with satin nickel base with three outputs, cil 16 mm connections included, and ceramic lamp holder module	E27	42W	1660	0,01	B62
SR3B/O/...	Spot con base in ottone anticato a tre uscite, comprensivo di raccordi cil 16 mm, e modulo portalamпада in ceramica / Spot with aged brass base with three outputs, cil 16 mm connections included, and ceramic lamp holder module	E27	42W	1660	0,01	B60
SR3B/NS/...	Spot con base in nichel satinato a tre uscite, comprensivo di raccordi cil 16 mm, e modulo portalamпада in ceramica / Spot with satin nickel base with three outputs, cil 16 mm connections included, and ceramic lamp holder module	E27	42W	1660	0,01	B62
SR4/O/...	Spot con base in ottone anticato a quattro uscite, comprensivo di raccordi cil 16 mm, e modulo portalamпада in ceramica / Spot with aged brass base with three outputs, cil 16 mm connections included, and ceramic lamp holder module	E27	42W	1660	0,01	B64
SR4/NS/...	Spot con base in nichel satinato a quattro uscite, comprensivo di raccordi cil 16 mm, e modulo portalamпада in ceramica / Spot with satin nickel base with four outputs, cil 16 mm connections included, and ceramic lamp holder module	E27	42W	1660	0,01	B66
LIN2/O/26	Canalina in ottone anticato, 16 mm diam. lunghezza 260 mm, interasse 400 mm Aged brass conduit 16 mm diam. length 260 mm, interaxis distance 400 mm *			460	0,01	B4
LIN2/NS/26	Canalina in nichel satinato, 16 mm. mm. diam. lunghezza 260 mm, interasse 400 mm Satin nickel conduit 16 mm diam. length 260 mm, interaxis distance 400 mm *			460	0,01	B5

CE IP20

Colore modulo portalamпада in ceramica
Ceramic lamp holder color

BL = Bianco lucido / Glossy white

NM = Nero matt / Matte Black

* A richiesta sono disponibili misure diverse
Upon request can be available different sizes

LINEA

Linea Modulare

sistema "Grafico" "Graphic" system

Composizione formata da spot e canaline da 8 mm. Nel sistema grafico SGA le uscite per la connessione alle canaline sono posizionate a 90° mentre nel sistema SGB le uscite sono a 75° e 105°. Lo spot comprensivo di raccordo. è formato da una base in ottone anticato o in cromo e da un modulo portalampada in ceramica con finitura bianco lucido o nero lucido. Può essere utilizzato come spot singolo o con varie uscite da 1 a 4.

Le canaline sono proposte in 3 forme diverse e nelle stesse finiture del portalampada.

The composition includes spot and conduits 8 mm. diam. In SGA graphic system outputs for conduit connection are placed at 90 degrees while in the SGB one outputs are at 75 and 105 degrees. The spot consists of a base in antique brass or chrome and from a ceramic lamp holder, glossy white or glossy black finishing. It can be used as a single spot or with more outputs. Conduits available in the same finishes lamp holder finishes.



Art. SGA4/CR/NL

Sistema SGA
SGA System



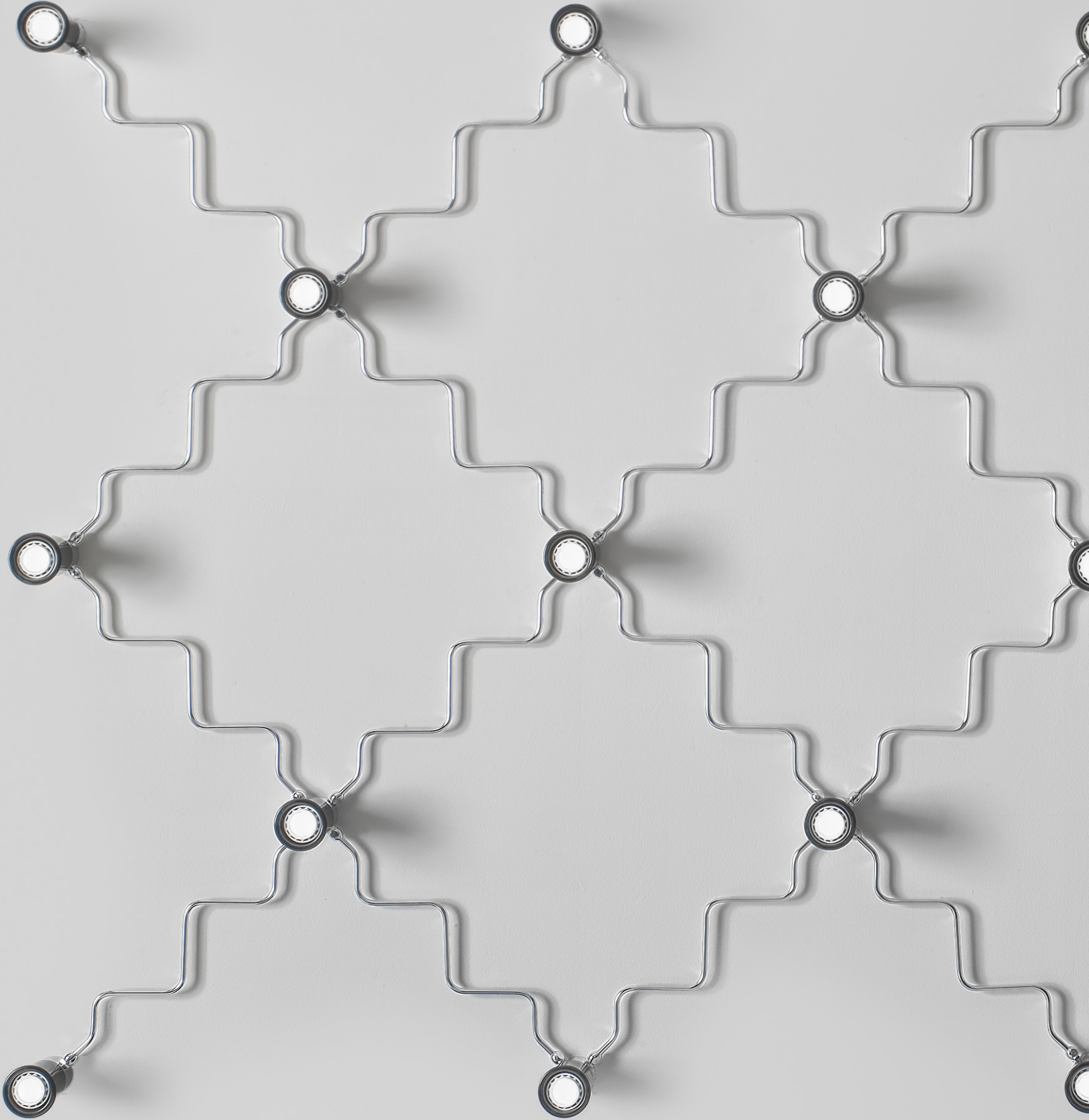

Sistema SGA
SGA System

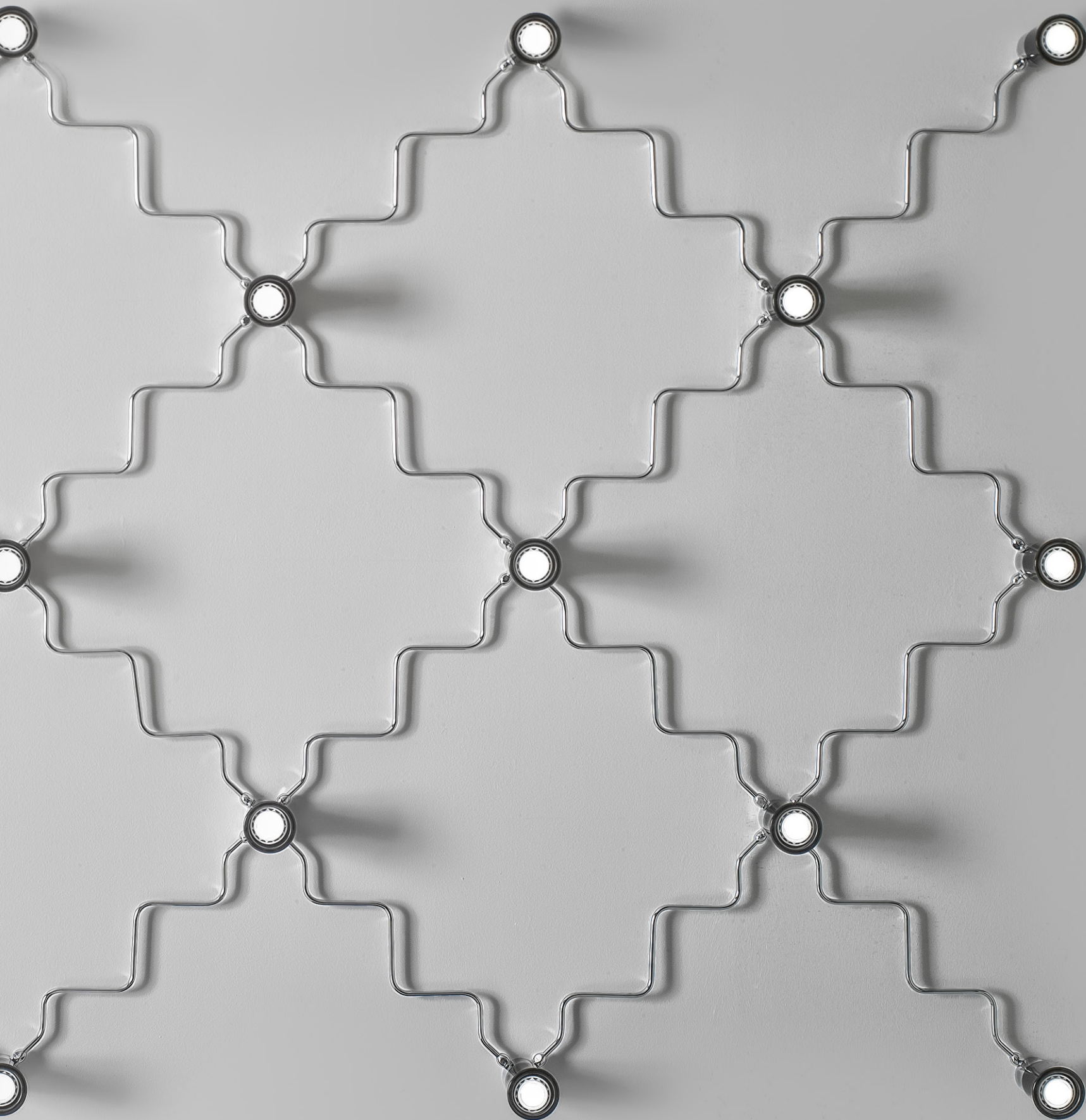

Sistema SGB
SGB System



Sistema SGB
SGB System

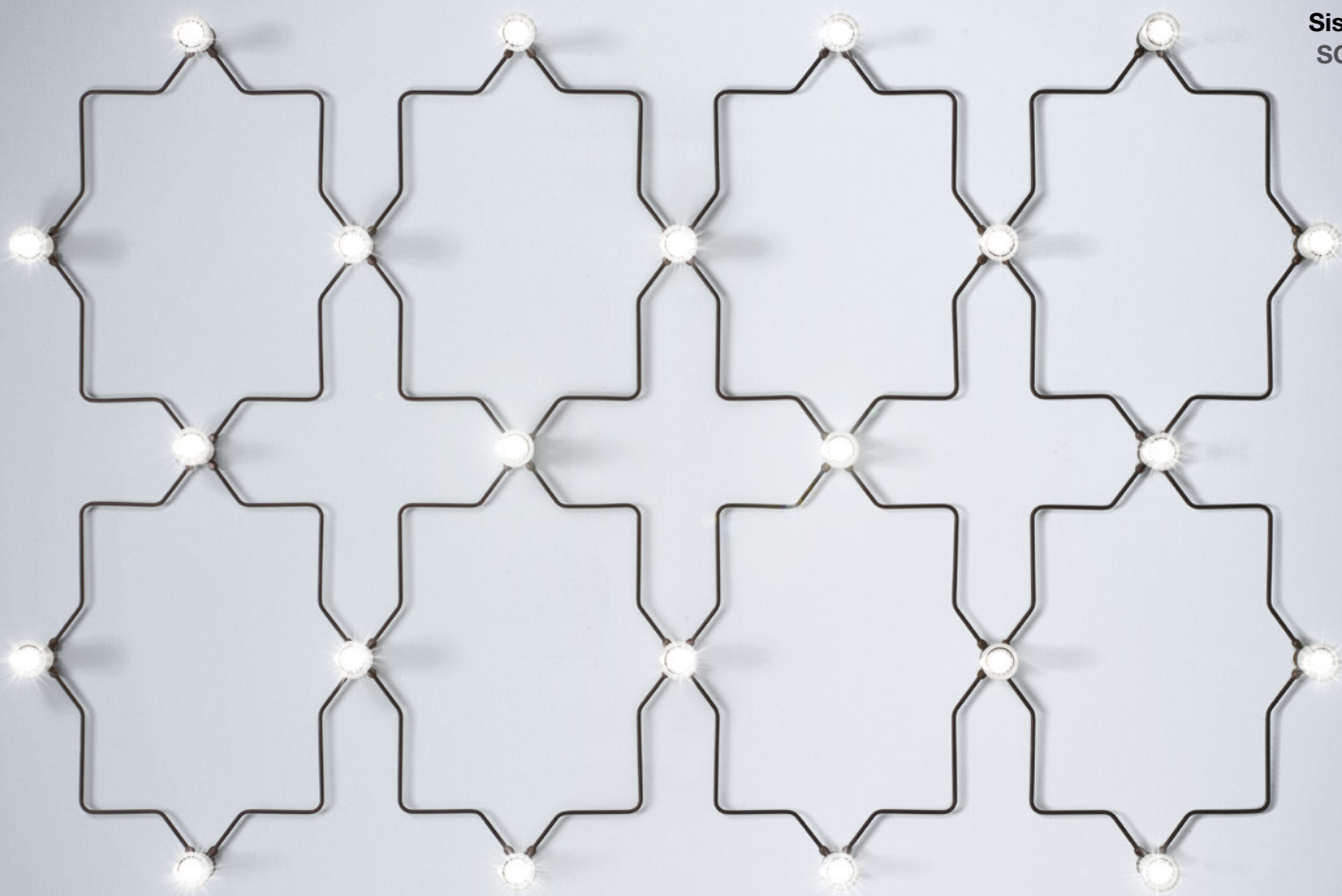



Sistema SGB
SGB System

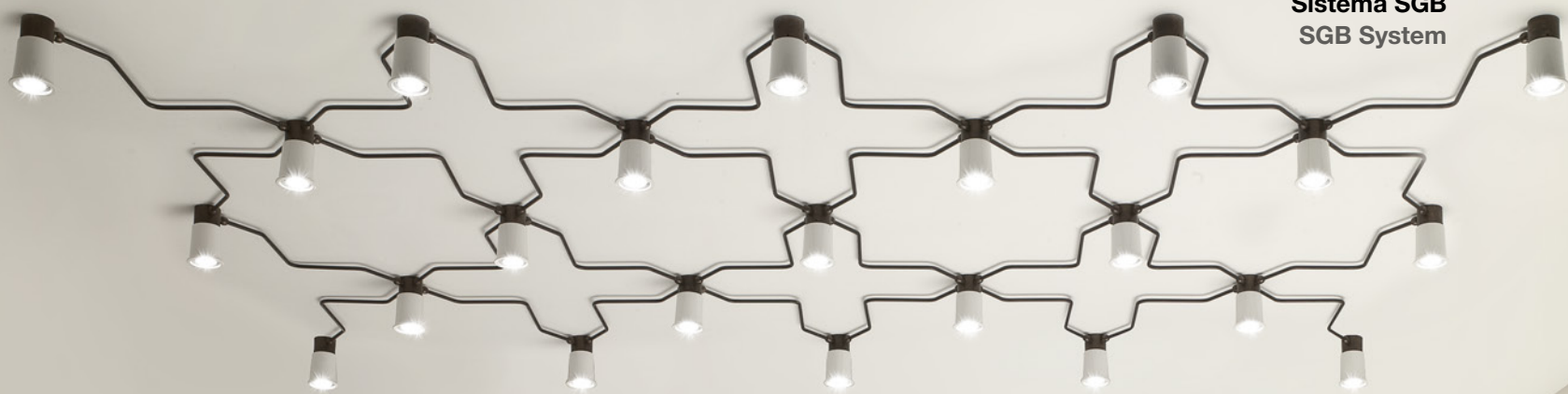



Canalette per
sistema grafico SGB

Conduits for SGB
graphic system

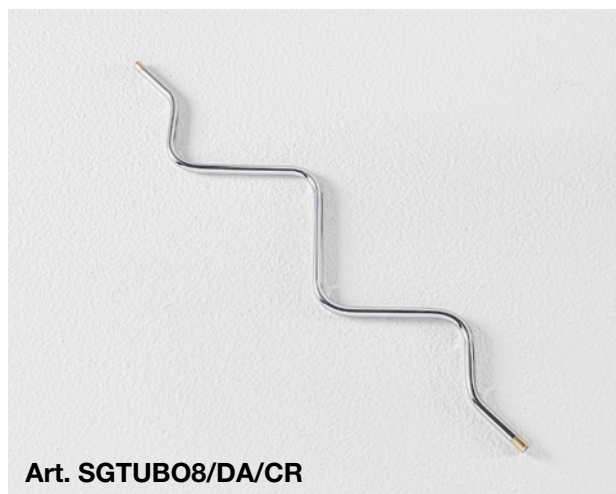
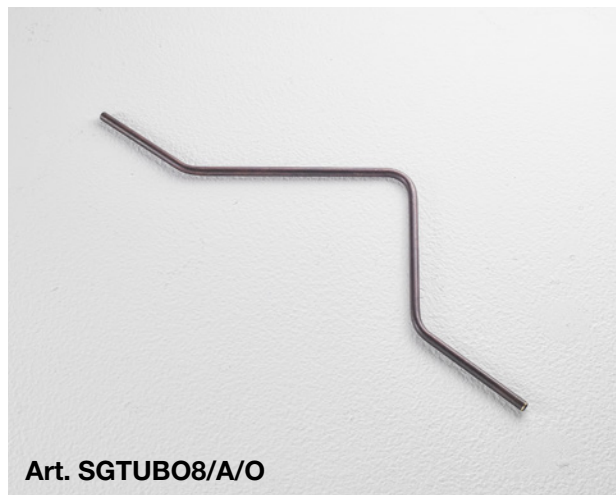

Canalette per
sistema grafico SGA

Conduits for SGA
graphic system

Sistema grafico SGA / SGA graphic system

Art. SGA/.../...

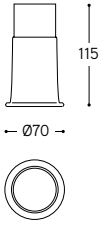

Art. SGA1/.../...

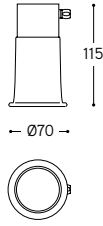

Art. SGA90/.../...

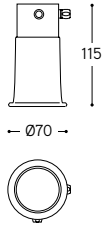

Art. SGA180/.../...

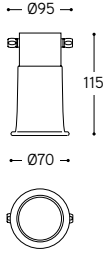

Art. SGA3/.../...

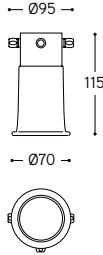

Art. SGA4/.../...

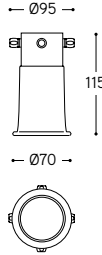

SGTUBO8/L/...

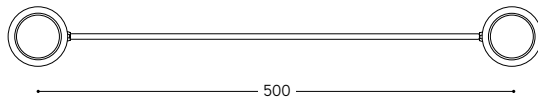
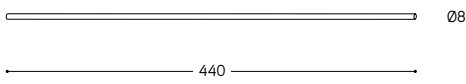

Art. SGTUBO8/A/...

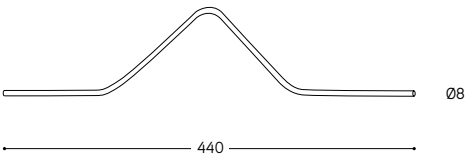

Art. SGTUBO8/DA/...

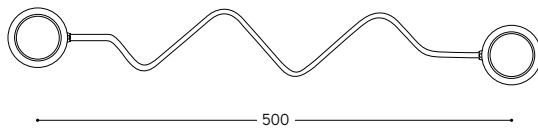
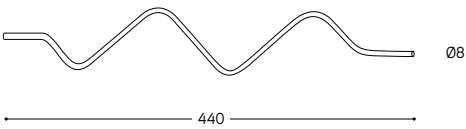

ARTICOLO ITEM	DESCRIZIONE DESCRIPTION	ATTACCO SOCKET	POTENZA POWER	PESO GR. WEIGHT GR.	VOL. IN M ³ VOL. IN M ³	FASCIA PREZZO PRICE RANGE
SGA/O/...	Spot con base in ottone anticato senza uscite e modulo portalampada in ceramica / Spot with aged brass base and ceramic lamp holder module	GU10	50W	680	0,01	B42
SGA/CR/...	Spot con base in cromo senza uscite e modulo portalampada in ceramica / Spot with chrome base and ceramic lamp holder module	GU10	50W	680	0,01	B43
SGA1/O/...	Spot con base in ottone anticato ad una uscita, comprensivo di raccordo 8 mm, e modulo portalampada in ceramica / Spot with aged brass base with single output, 8 mm connection included, and ceramic lamp holder module	GU10	50W	680	0,01	B44
SGA1/CR/...	Spot con base in cromo ad una uscita, comprensivo di raccordo 8 mm, e modulo portalampada in ceramica / Spot with chrome base with single output, 8 mm connection included, and ceramic lamp holder module	GU10	50W	680	0,01	B45
SGA90/O/...	Spot con base in ottone anticato a due uscite a 90°, comprensivo di raccordi 8 mm, e modulo portalampada in ceramica / Spot with aged brass base with two 90° outputs, 8 mm connections included, and ceramic lamp holder module	GU10	50W	680	0,01	B46
SGA90/CR/...	Spot con base in cromo a due uscite a 90°, comprensivo di raccordi 8 mm, e modulo portalampada in ceramica / Spot with chrome base with two 90° outputs, 8 mm connections included, and ceramic lamp holder module	GU10	50W	680	0,01	B48
SGA180/O/...	Spot con base in ottone anticato a due uscite a 180°, comprensivo di raccordi 8 mm, e modulo portalampada in ceramica / Spot with aged brass base with two 180° outputs, 8 mm connections included, and ceramic lamp holder module	GU10	50W	680	0,01	B46
SGA180/CR/...	Spot con base in cromo a due uscite a 180°, comprensivo di raccordi 8 mm, e modulo portalampada in ceramica / Spot with chrome base with two 180° outputs, 8 mm connections included, and ceramic lamp holder module	GU10	50W	680	0,01	B48
SGA3/O/...	Spot con base in ottone anticato a tre uscite, comprensivo di raccordi 8 mm, e modulo portalampada in ceramica / Spot with aged brass base with three outputs, 8 mm connections included, and ceramic lamp holder module	GU10	50W	680	0,01	B49
SGA3/CR/...	Spot con base in cromo a tre uscite, comprensivo di raccordi 8 mm, e modulo portalampada in ceramica / Spot with chrome base with three outputs, 8 mm connections included, and ceramic lamp holder module	GU10	50W	680	0,01	B51
SGA4/O/...	Spot con base in ottone anticato a quattro uscite, comprensivo di raccordi 8 mm, e modulo portalampada in ceramica / Spot with aged brass base with four outputs, 8 mm connections included, and ceramic lamp holder module	GU10	50W	680	0,01	B52
SGA4/CR/...	Spot con base in cromo a quattro uscite, comprensivo di raccordi 8 mm, e modulo portalampada in ceramica / Spot with chrome base with four outputs, 8 mm connections included, and ceramic lamp holder module	GU10	50W	680	0,01	B56
SGTUB08/L/O	Canalina lineare comprensiva di cavi di alimentazione, in ottone anticato, 8 mm diam. lunghezza 440 mm, interasse 500 mm / Linear aged brass conduit, supply leads included 8 mm diam. lenght 440 mm, interaxis distance 500 mm *			760	0,03	B5
SGTUB08/L/CR	Canalina lineare comprensiva di cavi di alimentazione, in cromo, 8 mm diam. lunghezza 440 mm, interasse 500 mm / Linear chrome conduit, supply leads included 8 mm diam. lenght 440 mm, interaxis distance 500 mm *			760	0,03	B8
SGTUB08/A/O	Canalina in ottone anticato sagomata, comprensiva di cavi di alimentazione, 8 mm diam. lunghezza 440 mm, interasse 500 mm / Shaped aged brass conduit, supply leads included, 8 mm diam. lenght 440 mm, interaxis distance 500 mm *			780	0,03	B13
SGATUB08/A/CR	Canalina in cromo sagomata, comprensiva di cavi di alimentazione, 8 mm diam. lunghezza 440 mm, interasse 500 mm / Shaped chrome conduit, supply leads included, 8 mm diam. lenght 440 mm, interaxis distance 500 mm *			780	0,03	B19
SGTUB08/DA/O	Canalina in ottone anticato sagomata, comprensiva di cavi di alimentazione, 8 mm diam. lunghezza 440 mm, interasse 500 mm / Shaped aged brass conduit, supply leads included, 8 mm diam. lenght 440 mm, interaxis distance 500 mm *			800	0,03	B13
SGTUB08/DA/CR	Canalina in cromo sagomata, comprensiva di cavi di alimentazione, 8 mm diam. lunghezza 440 mm, interasse 500 mm / Shaped chrome conduit, supply leads included, 8 mm diam. lenght 440 mm, interaxis distance 500 mm *			800	0,03	B19



Colore modulo portalampada in ceramica
Ceramic lamp holder color

/BL= Bianco lucido / Glossy white

/NL= Nero lucido / Glossy Black

* A richiesta sono disponibili misure diverse
Upon request can be available different sizes

Sistema grafico SGB / SGB graphic system

Art. SGB/.../...

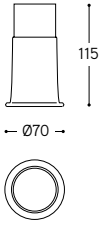

Art. SGB1/.../...

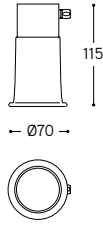

Art. SGB75/.../...

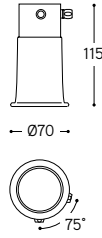

Art. SGB105/.../...

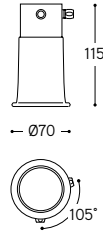

Art. SGB180/.../...

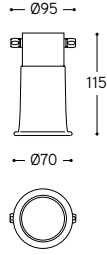

Art. SGB3A/.../...

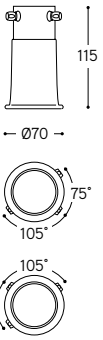

Art. SGB3B/.../...

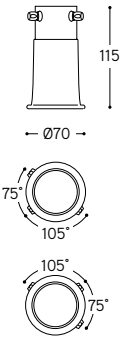

Art. SGB4/.../...

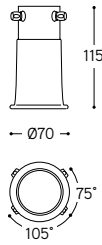

SGTUBO8/L/...

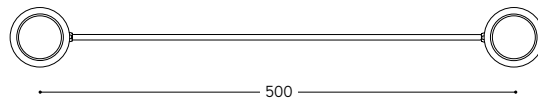
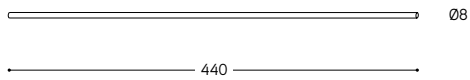

Art. SGTUBO8/A/...

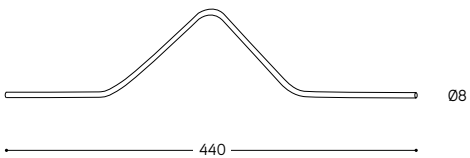

Art. SGTUBO8/DA/...

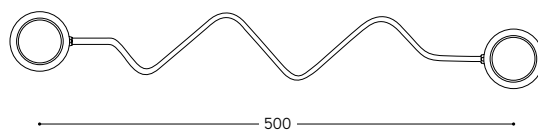
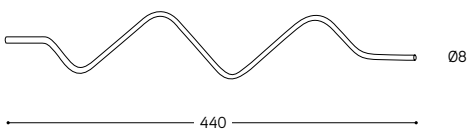

ARTICOLO ITEM	DESCRIZIONE DESCRIPTION	ATTACCO SOCKET	POTENZA POWER	PESO GR. WEIGHT GR.	VOL. IN M ³ VOL. IN M ³	FASCIA PREZZO PRICE RANGE
SGB/O/...	Spot con base in ottone anticato senza uscite e modulo portalampada in ceramica / Spot with aged brass base and ceramic lamp holder module	GU10	50W	680	0,01	B42
SGB/CR/...	Spot con base in cromo senza uscite e modulo portalampada in ceramica / Spot with chrome base and ceramic lamp holder module	GU10	50W	680	0,01	B43
SGB1/O/...	Spot con base in ottone anticato ad una uscita, comprensivo di raccordo 8 mm, e modulo portalampada in ceramica / Spot with aged brass base with single output, 8 mm connection included, and ceramic lamp holder module	GU10	50W	680	0,01	B44
SGB1/CR/...	Spot con base in cromo ad una uscita, comprensivo di raccordo 8 mm, e modulo portalampada in ceramica / Spot with chrome base with single output, 8 mm connection included, and ceramic lamp holder module	GU10	50W	680	0,01	B45
SGB75/O/...	Spot con base in ottone anticato a due uscite a 75°, comprensivo di raccordi 8 mm, e modulo portalampada in ceramica / Spot with aged brass base with two 75° outputs, 8 mm connections included, and ceramic lamp holder module	GU10	50W	680	0,01	B46
SGB75/CR/...	Spot con base in cromo a due uscite a 75°, comprensivo di raccordi 8 mm, e modulo portalampada in ceramica / Spot with chrome base with two 75° outputs, 8 mm connections included, and ceramic lamp holder module	GU10	50W	680	0,01	B48
SGB105/O/...	Spot con base in ottone anticato a due uscite a 105°, comprensivo di raccordi 8 mm, e modulo portalampada in ceramica / Spot with aged brass base with two 105° outputs, 8 mm connections included, and ceramic lamp holder module	GU10	50W	680	0,01	B46
SGB105/CR/...	Spot con base in cromo a due uscite a 105°, comprensivo di raccordi 8 mm, e modulo portalampada in ceramica / Spot with chrome base with two 105° outputs, 8 mm connections included, and ceramic lamp holder module	GU10	50W	680	0,01	B48
SGB180/O/...	Spot con base in ottone anticato a due uscite a 180°, comprensivo di raccordi 8 mm, e modulo portalampada in ceramica / Spot with aged brass base with two 180° outputs, 8 mm connections included, and ceramic lamp holder module	GU10	50W	680	0,01	B46
SGB180/CR/...	Spot con base in cromo a due uscite a 180°, comprensivo di raccordi 8 mm, e modulo portalampada in ceramica / Spot with chrome base with two 180° outputs, 8 mm connections included, and ceramic lamp holder module	GU10	50W	680	0,01	B48
SGB3A/O/...	Spot con base in ottone anticato a tre uscite, comprensivo di raccordi 8 mm, e modulo portalampada in ceramica / Spot with aged brass base with three outputs, 8 mm connections included, and ceramic lamp holder module	GU10	50W	680	0,01	B49
SGB3A/CR/...	Spot con base in cromo a tre uscite, comprensivo di raccordi 8 mm, e modulo portalampada in ceramica / Spot with chrome base with three outputs, 8 mm connections included, and ceramic lamp holder module	GU10	50W	680	0,01	B51
SGB3B/O/...	Spot con base in ottone anticato a tre uscite, comprensivo di raccordi 8 mm, e modulo portalampada in ceramica / Spot with aged brass base with three outputs, 8 mm connections included, and ceramic lamp holder module	GU10	50W	680	0,01	B49
SGB3B/CR/...	Spot con base in cromo a tre uscite, comprensivo di raccordi 8 mm, e modulo portalampada in ceramica / Spot with chrome base with three outputs, 8 mm connections included, and ceramic lamp holder module	GU10	50W	680	0,01	B51
SGB4/O/...	Spot con base in ottone anticato a quattro uscite, comprensivo di raccordi 8 mm, e modulo portalampada in ceramica / Spot with aged brass base with four outputs, 8 mm connections included, and ceramic lamp holder module	GU10	50W	680	0,01	B52
SGB4/CR/...	Spot con base in cromo a quattro uscite, comprensivo di raccordi 8 mm, e modulo portalampada in ceramica / Spot with chrome base with four outputs, 8 mm connections included, and ceramic lamp holder module	GU10	50W	680	0,01	B56
SGTUB08/L/O	Canalina lineare comprensiva di cavi di alimentazione, in ottone anticato, 8 mm diam. lunghezza 440 mm, interasse 500 mm / Linear aged brass conduit, supply leads included 8 mm diam. length 440 mm, interaxis distance 500 mm *			760	0,03	B5
SGTUB08/L/CR	Canalina lineare comprensiva di cavi di alimentazione, in cromo, 8 mm diam. lunghezza 440 mm, interasse 500 mm / Linear chrome conduit, supply leads included 8 mm diam. length 440 mm, interaxis distance 500 mm *			760	0,03	B8
SGTUB08/A/O	Canalina in ottone anticato sagomata, comprensiva di cavi di alimentazione, 8 mm diam. lunghezza 440 mm, interasse 500 mm / Shaped aged brass conduit, supply leads included, 8 mm diam. length 440 mm, interaxis distance 500 mm *			780	0,03	B13
SGTUB08/A/CR	Canalina in cromo sagomata, comprensiva di cavi di alimentazione, 8 mm diam. lunghezza 440 mm, interasse 500 mm / Shaped chrome conduit, supply leads included, 8 mm diam. length 440 mm, interaxis distance 500 mm *			780	0,03	B19

CE ⊕ IP20  

Colore modulo portalampada in ceramica
Ceramic lamp holder color

BL = Bianco lucido / Glossy white

NL = Nero lucido / Glossy Black

* A richiesta sono disponibili misure diverse
Upon request can be available different sizes

LINEA

Linea Modulare

sistema Ibrido

Ibrido system

Composizione formata da una o più sospensioni collegati da cavo colorato.

La sospensione è formato da una base con gancio in ottone anticato e da un modulo portalamпада in ceramica bianco lucido o con decoro filo colorato.

Il cavo, da ordinare a parte, è disponibile in vari colori, da specificare al momento dell'ordine. Da ordinare a parte è anche l'eventuale rosone presente a pagina 126.

Composition consisting of one or more pendants, connected by colored cable.

The pendant consists of a base with hook in aged brass and a lamp holder ceramic module available in glossy white or colored line finishing.

The cable, to be ordered separately, is available in several colors, to specify when ordering.

The eventual ceiling rose, to be ordered separately, can find at pag. 126

4) Art. SIB/BL/FR
5 MT) Art. C.R/MT
1) Art. LAR.02.FR





Art. SIB/...

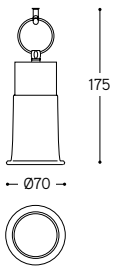

Art. SIB1/...

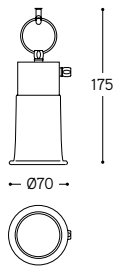

Art. SIB90/...

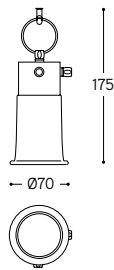

Art. SIB180/...

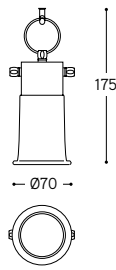

Art. SIB3/...

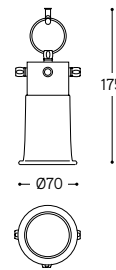

Art. SIB4/...

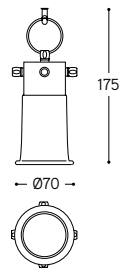

Cavo in cotone / Cotton cable



C.A
Cavo azzurro / Blue cable



C.G
Cavo giallo / Yellow cable



C.N
Cavo nero / Black cable



C.B
Cavo bianco / White cable



C.R
Cavo rosso / Red cable

ARTICOLO ITEM	DESCRIZIONE DESCRIPTION	SEZ. IN MM SECT. IN MM	PESO GR. WEIGHT GR.	VOL. IN M ³ VOL. IN M ³	PEZZI IMBALLO OUTER BOX	FASCIA PREZZO PRICE RANGE
C.A/CONF	Cavo azzurro / Blue cable	2x0,75	3020	0,02	1 matassa da 50 mt / 50 mt roll	B66
C.G/CONF	Cavo giallo / Yellow cable	2x0,75	3020	0,02	1 matassa da 50 mt / 50 mt roll	B66
C.N/CONF	Cavo nero / Black cable	2x0,75	3020	0,02	1 matassa da 50 mt / 50 mt roll	B66
C.B/CONF	Cavo bianco / White cable	2x0,75	3020	0,02	1 matassa da 50 mt / 50 mt roll	B66
C.R/CONF	Cavo rosso / Red cable	2x0,75	3020	0,02	1 matassa da 50 mt / 50 mt roll	B66
C.A/MT	Cavo azzurro / Blue cable	2x0,75	110	0,001	1 mt	B4
C.G/MT	Cavo giallo / Yellow cable	2x0,75	110	0,001	1 mt	B4
C.N/MT	Cavo nero / Black cable	2x0,75	110	0,001	1 mt	B4
C.B/MT	Cavo bianco / White cable	2x0,75	110	0,001	1 mt	B4
C.R/MT	Cavo rosso / Red cable	2x0,75	110	0,001	1 mt	B4

ARTICOLO ITEM	DESCRIZIONE DESCRIPTION	ATTACCO SOCKET	POTENZA POWER	PESO GR. WEIGHT GR.	VOL. IN M ³ VOL. IN M ³	FASCIA PREZZO PRICE RANGE
SIB/BL	Sospensione con rosone e base in ottone anticato e con modulo portalampada in ceramica bianco lucido / Pendant with aged brass canopy and base and with glossy white ceramic lamp holder module	E27	42W	980	0,01	B50
SIB/BL/...	Sospensione con rosone e base in ottone anticato e con modulo portalampada in ceramica decoro filo colorato / Pendant with aged brass canopy and base and with lamp holder ceramic module in coloured line finish	E27	42W	980	0,01	B50
SIB/NL	Sospensione con rosone e base in ottone anticato e con modulo portalampada in ceramica nero lucido / Pendant with aged brass canopy and base and with glossy black ceramic lamp holder module	E27	42W	980	0,01	B50
SIB1/BL	Sospensione con rosone e base in ottone anticato ad una uscita, comprensiva di raccordo e con modulo portalampada in ceramica bianco lucido / Pendant with aged brass canopy and base, with single output, connection included, and with glossy white ceramic lamp holder module	E27	42W	980	0,01	B52
SIB1/BL/...	Sospensione con rosone e base in ottone anticato ad una uscita, comprensiva di raccordo e con modulo portalampada in ceramica decoro filo colorato / Pendant with aged brass canopy and base, with single output, connection included, and with lamp holder ceramic module in coloured line finish	E27	42W	980	0,01	B52
SIB1/NL	Sospensione con rosone e base in ottone anticato ad una uscita, comprensiva di raccordo e con modulo portalampada in ceramica nero lucido / Pendant with aged brass canopy and base, with single output, connection included, and with glossy black ceramic lamp holder module	E27	42W	980	0,01	B52
SIB90/BL	Sospensione con rosone e base in ottone anticato a due uscite a 90°, comprensiva di raccordo e con modulo portalampada in ceramica bianco lucido / Pendant with aged brass canopy and base, with two 90° outputs, connections included, and with glossy white ceramic lamp holder module	E27	42W	980	0,01	B55
SIB90/BL/...	Sospensione con rosone e base in ottone anticato a due uscite a 90°, comprensiva di raccordo e con modulo portalampada in ceramica decoro filo colorato / Pendant with aged brass canopy and base, with two 90° outputs, connections included, and with lamp holder ceramic module in coloured line finish	E27	42W	980	0,01	B55
SIB90/NL	Sospensione con rosone e base in ottone anticato a due uscite a 90°, comprensiva di raccordo e con modulo portalampada in ceramica nero lucido / Pendant with aged brass canopy and base, with two 90° outputs, connections included, and with glossy black ceramic lamp holder module	E27	42W	980	0,01	B55
SIB180/BL	Sospensione con rosone e base in ottone anticato a due uscite a 180°, comprensiva di raccordo e con modulo portalampada in ceramica bianco lucido / Pendant with aged brass canopy and base, with two 180° outputs, connections included, and with glossy white ceramic lamp holder module	E27	42W	980	0,01	B55
SIB180/BL/...	Sospensione con rosone e base in ottone anticato a due uscite a 180°, comprensiva di raccordo e con modulo portalampada in ceramica decoro filo colorato / Pendant with aged brass canopy and base, with two 180° outputs, connections included, and with lamp holder ceramic module in coloured line finish	E27	42W	980	0,01	B55
SIB180/NL	Sospensione con rosone e base in ottone anticato a due uscite a 180°, comprensiva di raccordo e con modulo portalampada in ceramica nero lucido / Pendant with aged brass canopy and base, with two 180° outputs, connections included, and with glossy black ceramic lamp holder module	E27	42W	980	0,01	B55
SIB3/BL	Sospensione con rosone e base in ottone anticato a tre uscite, comprensiva di raccordo e con modulo portalampada in ceramica bianco lucido / Pendant with aged brass canopy and base, with three outputs, connections included, and with glossy white ceramic lamp holder module	E27	42W	980	0,01	B58
SIB3/BL/...	Sospensione con rosone e base in ottone anticato a tre uscite, comprensiva di raccordo e con modulo portalampada in ceramica decoro filo colorato / Pendant with aged brass canopy and base, with three outputs, connections included, and with lamp holder ceramic module in coloured line finish	E27	42W	980	0,01	B58
SIB3/NL	Sospensione con rosone e base in ottone anticato a tre uscite, comprensiva di raccordo e con modulo portalampada in ceramica nero lucido / Pendant with aged brass canopy and base, with three outputs, connections included, and with glossy black ceramic lamp holder module	E27	42W	980	0,01	B58
SIB4/BL	Sospensione con rosone e base in ottone anticato a quattro uscite, comprensiva di raccordo e con modulo portalampada in ceramica bianco lucido / Pendant with aged brass canopy and base, with four outputs, connections included, and with glossy white ceramic lamp holder module	E27	42W	980	0,01	B59
SIB4/BL/...	Sospensione con rosone e base in ottone anticato a quattro uscite, comprensiva di raccordo e con modulo portalampada in ceramica decoro filo colorato / Pendant with aged brass canopy and base, with four outputs, connections included, and with lamp holder ceramic module in coloured line finish	E27	42W	980	0,01	B59
SIB4/NL	Sospensione con rosone e base in ottone anticato a quattro uscite, comprensiva di raccordo e con modulo portalampada in ceramica nero lucido / Pendant with aged brass canopy and base, with four outputs, connections included, and with glossy black ceramic lamp holder module	E27	42W	980	0,01	B59

CE IP20

Fili colorati / Coloured lines

/... **FR** = Filo rosso / Red line

/... **FN** = Filo nero / Black line

/... **FG** = Filo giallo / Yellow line



IMPIANTO A TRECCIA BRAID SYSTEM

L'impianto a treccia si propone di soddisfare le esigenze di coloro che desiderano ristrutturare ambienti nell'ottica della funzionalità, nella riscoperta delle tradizioni e nella più completa sicurezza in conformità alle norme vigenti. Lasciamoci avvolgere dal calore di questi oggetti e dalle loro forme.

The system with braid is suitable to satisfy each requirement of environment reconstruction considering the functionality, rediscovering traditions and not forgetting security in conformity with the current standard norms. Let us surround by the warmth sensation and shapes of these objects.

L'appliche della linea "Bilancia" viene personalizzata con il nome della location.

The line "Bilancia" wall lamp is personalized with the name of the location.



L'articolo 3000CV e le sospensioni linea "Tesa" arredano "La chambre de Marie" e "La Rue" di questo particolare ristorante di Poitiers.

Article 3000CV and pendants line "Tesa" furnish "La chambre de Marie" and "La Rue" of this glamorous restaurant located in Poitiers.





Antica Osteria "Al Baccaro": sotto al portico che porta alla bella piazza di Asolo si trova questo locale tipico dove gli articoli della linea "Tesa" trovano la loro corretta collocazione. Queste lampade enfatizzano lo stile della location e il suo carattere familiare.

Antique Osteria "Al Baccaro" under the portico leading to the beautiful square of Asolo is the typical place where line "Tesa" articles find their proper place. These lamps emphasize the style of the location and its family character.



Le linee qui di seguito presentate rispondono ad un ideale di signorilità, suscitano ammirazione e piacere estetico, nel rispetto delle tradizioni. La nostra esperienza come produttori di apparecchi per illuminazione è messa a disposizione di progettisti ed installatori e propone valide alternative alle esigenze di ristrutturazione.



These series meet an ideal style, provoke admiration and aesthetic pleasure respecting tradition. We offer our lighting fixtures manufacturers experience to designers and installers and we propose valid alternatives to restructuring requirements.



L'impianto "a treccia" è il corretto connubio tra tecnologia moderna e valore antico. Tutta la magia della luce racchiusa in una linea che illuminerà il vostro sguardo sul mondo.

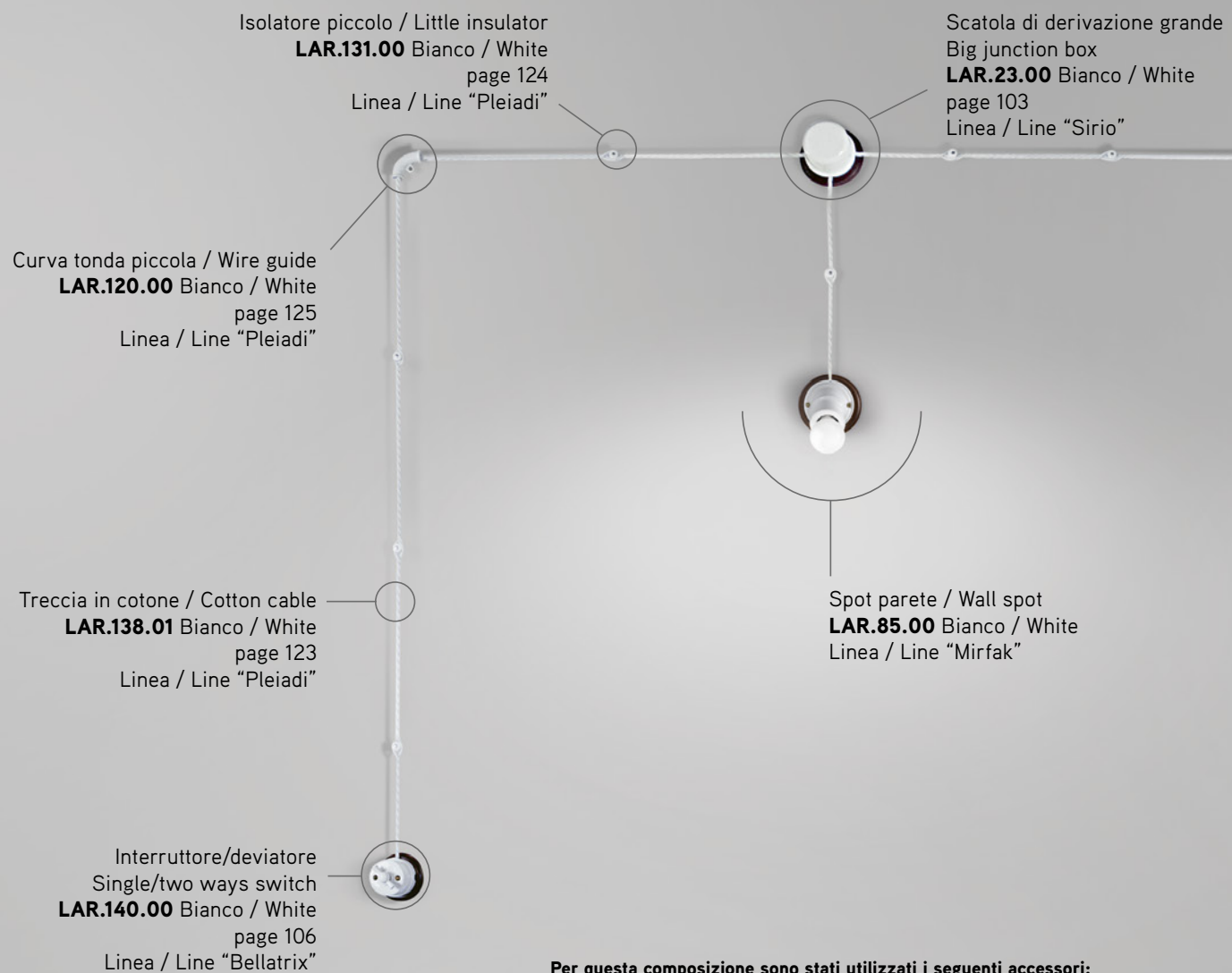

Per questa composizione sono stati utilizzati i seguenti accessori:

- N° 3 scatole di derivazione in ceramica bianca (**LAR.23.00** linea Sirio)
- N° 2 spot a una luce in ceramica bianca (**LAR.85.00** linea Mirfak)
- N° 5 rosette in legno grandi (**LAR.134.B** linea Pleiadi)
- N° 1 interruttore/deviatore in ceramica bianca (**LAR.140.00** Linea Bellatrix)
- N° 2 interruttori/deviatori in ceramica bianca con farfallina in ottone anticato (**LAR.20.00** linea Sirio)
- N° 3 rosette in legno piccole (**LAR.134.A** linea Pleiadi)
- N° 2 curve rette grandi in ceramica bianca (**LAR.116.00** linea Pleiadi)
- N° 1 curva tonda piccola in ceramica bianca (**LAR.120.00** linea Pleiadi)
- N° 15 isolatori in ceramica bianca (**LAR.131.00** linea Pleiadi)
- N° 3 isolatori doppi in ceramica bianca (**LAR.132.00** linea Pleiadi)
- 7 metri treccia in cotone bianco (**LAR.138.01** sezione 3 x 0,75 linea Pleiadi)

LINEA
Castore

Serie composta da interruttori, prese e scatola di derivazione. Per tutti gli articoli della serie è prevista la variante in ceramica bianca e cotto. Gli articoli della serie sono comprensivi di frutto interno e possono essere corredati con particolari di nostra produzione della serie "Pleiadi", da ordinare a parte.

Ceramic surface mounted switches, sockets and junction box. Articles can be supplied in white ceramic or cotto ceramic. They can be combined with the "Pleiadi" accessories, to be ordered separately.



Art. LAR.187.C
Art. LAR.134.A
Art. LAR.131.C
Art. LAR.138.03



Interruttore / Deviatore Single/two ways switch

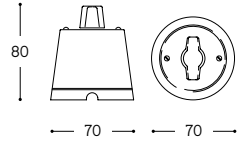

ARTICOLO ITEM	V	A	PESO GR. WEIGHT GR.	VOL. IN M ³ VOL. IN M ³	PEZZI IMBALLO OUTER BOX	FASCIA PREZZO PRICE RANGE
LAR.187.00 Bianco / White	250	10	234	0,001	1	B19
LAR.187.C Cotto / Cotto						



Variatore luminosità Rotary dimmer switch

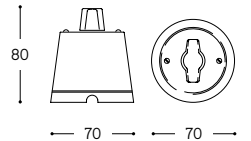

ARTICOLO ITEM	VA	PESO GR. WEIGHT GR.	VOL. IN M ³ VOL. IN M ³	PEZZI IMBALLO OUTER BOX	FASCIA PREZZO PRICE RANGE
LAR.187.00/DIMMER Bianco / White	400	269	0,001	1	B35
LAR.187.C/DIMMER Cotto / Cotto					



Presa bipasso Two ways socket

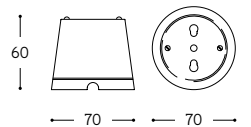

ARTICOLO ITEM	V	A	PESO GR. WEIGHT GR.	VOL. IN M ³ VOL. IN M ³	PEZZI IMBALLO OUTER BOX	FASCIA PREZZO PRICE RANGE
LAR.188.00 Bianco / White	250	16	224	0,001	1	B19
LAR.188.C Cotto / Cotto						



Presa Internet RJ45 Internet socket RJ45

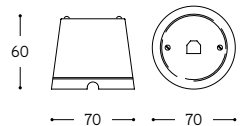

ARTICOLO ITEM	PESO GR. WEIGHT GR.	VOL. IN M ³ VOL. IN M ³	PEZZI IMBALLO OUTER BOX	FASCIA PREZZO PRICE RANGE
LAR.188.00/INTE Bianco / White	222	0,001	1	B35
LAR.188.C/INTE Cotto / Cotto				



Presa telefono RJ11 Telephone socket RJ11

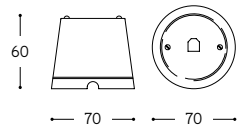

ARTICOLO ITEM	PESO GR. WEIGHT GR.	VOL. IN M ³ VOL. IN M ³	PEZZI IMBALLO OUTER BOX	FASCIA PREZZO PRICE RANGE
LAR.188.00/TEL Bianco / White	210	0,001	1	B19
LAR.188.C/TEL Cotto / Cotto				



Presa coassiale TV/SAT TV/SAT coaxial socket

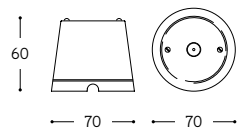

ARTICOLO ITEM	PESO GR. WEIGHT GR.	VOL. IN M ³ VOL. IN M ³	PEZZI IMBALLO OUTER BOX	FASCIA PREZZO PRICE RANGE
LAR.188.00/TV/SAT Bianco / White	214	0,001	1	B19
LAR.188.C/TV/SAT Cotto / Cotto				



Scatola di derivazione Ceramic junction box

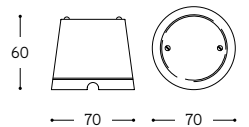

ARTICOLO ITEM	PESO GR. WEIGHT GR.	VOL. IN M ³ VOL. IN M ³	PEZZI IMBALLO OUTER BOX	FASCIA PREZZO PRICE RANGE
LAR.189.00 Bianco / White	202	0,001	1	B13
LAR.189.C Cotto / Cotto				



Art. LAR.191.00
Art. LAR.134.A

Art. LAR.190.00
Art. LAR.134.A

Art. LAR.132.00
Art. LAR.138.02

LINEA Polluce

Serie composta da interruttore, prese e scatola di derivazione. Per tutti gli articoli della serie è prevista la variante in ceramica bianca e cotto. Gli articoli della serie sono comprensivi di frutto interno e possono essere corredati con particolari di nostra produzione della serie "Pleiadi", da ordinare a parte.

Ceramic surface mounted switch, sockets and junction box. Articles can be supplied in white ceramic or cotto ceramic. They can be combined with the "Pleiadi" accessories, to be ordered separately.



Interruttore / Deviatore Single/two ways switch

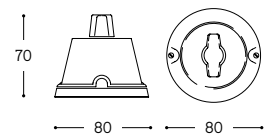

ARTICOLO ITEM	V	A	PESO GR. WEIGHT GR.	VOL. IN M ³ VOL. IN M ³	PEZZI IMBALLO OUTER BOX	FASCIA PREZZO PRICE RANGE
LAR.190.00 Bianco / White	250	10	246	0,001	1	B19
LAR.190.C Cotto / Cotto						



Presa bipasso Two ways socket

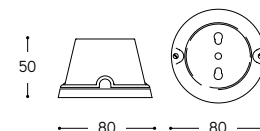

ARTICOLO ITEM	V	A	PESO GR. WEIGHT GR.	VOL. IN M ³ VOL. IN M ³	PEZZI IMBALLO OUTER BOX	FASCIA PREZZO PRICE RANGE
LAR.191.00 Bianco / White	250	16	236	0,001	1	B19
LAR.191.C Cotto / Cotto						



Presa telefono RJ11 Telephone socket RJ11

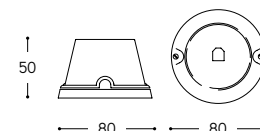

ARTICOLO ITEM	PESO GR. WEIGHT GR.	VOL. IN M ³ VOL. IN M ³	PEZZI IMBALLO OUTER BOX	FASCIA PREZZO PRICE RANGE
LAR.191.00/TEL Bianco / White	216	0,001	1	B19
LAR.191.C/TEL Cotto / Cotto				



Presa coassiale TV/SAT TV/SAT coaxial socket

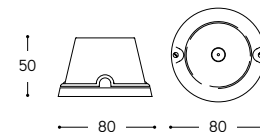

ARTICOLO ITEM	PESO GR. WEIGHT GR.	VOL. IN M ³ VOL. IN M ³	PEZZI IMBALLO OUTER BOX	FASCIA PREZZO PRICE RANGE
LAR.191.00/TV/SAT Bianco / White	230	0,001	1	B19
LAR.191.C/TV/SAT Cotto / Cotto				



Scatola di derivazione Ceramic junction box

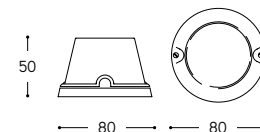

ARTICOLO ITEM	PESO GR. WEIGHT GR.	VOL. IN M ³ VOL. IN M ³	PEZZI IMBALLO OUTER BOX	FASCIA PREZZO PRICE RANGE
LAR.192.00 Bianco / White	216	0,001	1	B13
LAR.192.C Cotto / Cotto				

LINEA
Antares

Serie composta da interruttore/deviatore, prese e scatole di derivazione grande e piccola. I materiali utilizzati sono la ceramica bianca, la ceramica decorata con filo colorato o la ceramica - cotto. Gli articoli della serie sono comprensivi di frutto interno e possono essere corredati con particolari di nostra produzione della serie "Pleiadi", da ordinare a parte.

Ceramic surface mounted switch, sockets and big or little junction box. Articles can be supplied in different versions: white ceramic, coloured line ceramic or cotto ceramic. They can be combined with the "Pleiadi" accessories, to be ordered separately.

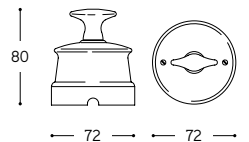
Interruttore / Deviatore
Single/two ways switch

ARTICOLO ITEM	V	A	PESO GR. WEIGHT GR.	VOL. IN M ³ VOL. IN M ³	PEZZI IMBALLO OUTER BOX	FASCIA PREZZO PRICE RANGE
LAR.10.00 Bianco / White						
LAR.10. ... Filo colorato / Coloured line (*)	250	10	240	0,001	1	B30
LAR.10.C Cotto / Cotto						



Presa bipasso Two ways socket

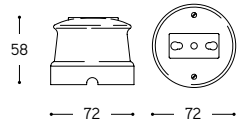

ARTICOLO ITEM	V	A	PESO GR. WEIGHT GR.	VOL. IN M ³ VOL. IN M ³	PEZZI IMBALLO OUTER BOX	FASCIA PREZZO PRICE RANGE
LAR.15.00 Bianco / White						
LAR.15. ... Filo colorato / Coloured line (*)	250	16	224	0,001	1	B23
LAR.15.C Cotto / Cotto						



Presa telefono RJ11 Telephone socket RJ11

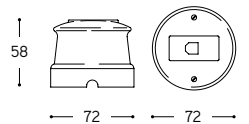

ARTICOLO ITEM	PESO GR. WEIGHT GR.	VOL. IN M ³ VOL. IN M ³	PEZZI IMBALLO OUTER BOX	FASCIA PREZZO PRICE RANGE
LAR.15.00/TEL Bianco / White				
LAR.15. .../TEL Filo colorato / Coloured line (*)	214	0,001	1	B23
LAR.15.C/TEL Cotto / Cotto				



Presa coassiale TV/SAT TV/SAT coaxial socket

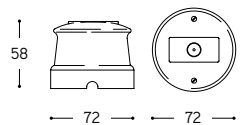

ARTICOLO ITEM	PESO GR. WEIGHT GR.	VOL. IN M ³ VOL. IN M ³	PEZZI IMBALLO OUTER BOX	FASCIA PREZZO PRICE RANGE
LAR.15.00/TV/SAT Bianco / White				
LAR.15. .../TV/SAT Filo colorato / Coloured line (*)	218	0,001	1	B23
LAR.15.C/TV/SAT Cotto / Cotto				



Scatola di derivazione Ceramic junction box

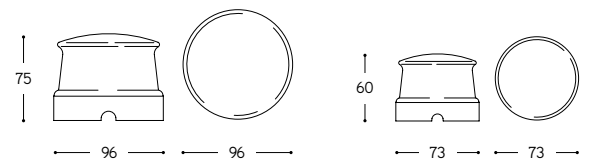

ARTICOLO ITEM	PESO GR. WEIGHT GR.	VOL. IN M ³ VOL. IN M ³	PEZZI IMBALLO OUTER BOX	FASCIA PREZZO PRICE RANGE
LAR.13.00 Grande Bianca / Big White				
LAR.13. ... Grande filo colorato / Big coloured line (*)	354	0,002	1	B19
LAR.13.C Grande Cotto / Big Cotto				
LAR.12.00 Piccola Bianca / Small White				
LAR.12. ... Piccola filo colorato / Small coloured line (*)	188	0,001	1	B13
LAR.12.C Piccola Cotto / Small Cotto				

(*) ... FR = Filo rosso / Red line
 ... FM = Filo marrone / Brown line
 ... FA = Filo ramina / Green line
 ... FB = Filo blu / Blue line
 ... FO = Filo arancio / Orange line

Art. LAR.20.C
Art. LAR.134.A

Art. LAR.131.C
Art. LAR.138.03

LINEA Sirio

Serie composta da interruttore/deviatore, prese e scatole di derivazione grande e piccola. I materiali utilizzati sono la ceramica bianca, la ceramica decorata con filo colorato o la ceramica - cotto. Gli articoli della serie sono comprensivi di frutto interno e possono essere corredati con particolari di nostra produzione della serie "Pleiadi", da ordinare a parte.

Ceramic surface mounted switch, sockets and big or little junction box. Articles can be supplied in different versions: white ceramic, coloured line ceramic or cotto ceramic. They can be combined with the "Pleiadi" accessories, to be ordered separately.



Interruttore / Deviatore Single/two ways switch

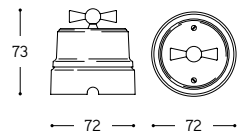

ARTICOLO ITEM	V	A	PESO GR. WEIGHT GR.	VOL. IN M ³ VOL. IN M ³	PEZZI IMBALLO OUTER BOX	FASCIA PREZZO PRICE RANGE
LAR.20.00 Bianco / White						
LAR.20. ... Filo colorato / Coloured line (*)	250	10	260	0,001	1	B30
LAR.20.C Cotto / Cotto						



Presa bipasso Two ways socket

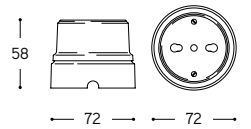

ARTICOLO ITEM	V	A	PESO GR. WEIGHT GR.	VOL. IN M ³ VOL. IN M ³	PEZZI IMBALLO OUTER BOX	FASCIA PREZZO PRICE RANGE
LAR.25.00 Bianco / White						
LAR.25. ... Filo colorato / Coloured line (*)	250	16	242	0,001	1	B23
LAR.25.C Cotto / Cotto						



Presa telefono RJ11 Telephone socket RJ11

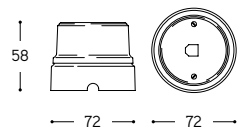

ARTICOLO ITEM	PESO GR. WEIGHT GR.	VOL. IN M ³ VOL. IN M ³	PEZZI IMBALLO OUTER BOX	FASCIA PREZZO PRICE RANGE
LAR.25.00/TEL Bianco / White				
LAR.25. .../TEL Filo colorato / Coloured line (*)	226	0,001	1	B23
LAR.25.C/TEL Cotto / Cotto				



Presa coassiale TV/SAT TV/SAT coaxial socket

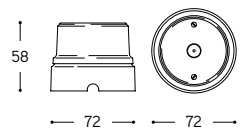

ARTICOLO ITEM	PESO GR. WEIGHT GR.	VOL. IN M ³ VOL. IN M ³	PEZZI IMBALLO OUTER BOX	FASCIA PREZZO PRICE RANGE
LAR.25.00/TV/SAT Bianco / White				
LAR.25. .../TV/SAT Filo colorato / Coloured line (*)	230	0,001	1	B23
LAR.25.C/TV/SAT Cotto / Cotto				



Scatola di derivazione Ceramic junction box

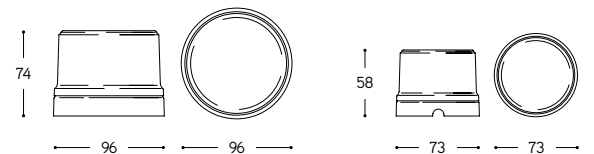

ARTICOLO ITEM	PESO GR. WEIGHT GR.	VOL. IN M ³ VOL. IN M ³	PEZZI IMBALLO OUTER BOX	FASCIA PREZZO PRICE RANGE
LAR.23.00 Grande Bianca / Big White				
LAR.23. ... Grande filo colorato / Big coloured line (*)	346	0,002	1	B19
LAR.23.C Grande Cotto / Big Cotto				
LAR.22.00 Piccola Bianca / Small White				
LAR.22. ... Piccola filo colorato / Small coloured line (*)	198	0,001	1	B13
LAR.22.C Piccola Cotto / Small Cotto				

(*) ... FR = Filo rosso / Red line
 ... FM = Filo marrone / Brown line
 ... FA = Filo ramina / Green line
 ... FB = Filo blu / Blue line
 ... FO = Filo arancio / Orange line

Art. LAR.30.FM
Art. LAR.134.A

Art. LAR.138.02

LINEA Rigel

Serie composta da interruttore/deviatore, prese e scatole di derivazione grande e piccola. I materiali utilizzati sono la ceramica bianca, la ceramica decorata con filo colorato o la ceramica - cotto. Gli articoli della serie sono comprensivi di frutto interno e possono essere corredati con particolari di nostra produzione della serie "Pleiadi", da ordinare a parte.

Ceramic surface mounted switch, sockets and big or little junction box. Articles can be supplied in different versions: white ceramic, coloured line ceramic or cotto ceramic. They can be combined with the "Pleiadi" accessories, to be ordered separately.



Interruttore / Deviatore Single/two ways switch

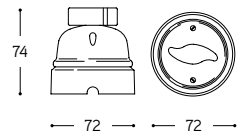

ARTICOLO ITEM	V	A	PESO GR. WEIGHT GR.	VOL. IN M ³ VOL. IN M ³	PEZZI IMBALLO OUTER BOX	FASCIA PREZZO PRICE RANGE
LAR.30.00 Bianco / White						
LAR.30. ... Filo colorato / Coloured line (*)	250	10	234	0,001	1	B30
LAR.30.C Cotto / Cotto						



Presa bipasso Two ways socket

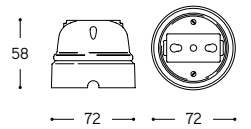

ARTICOLO ITEM	V	A	PESO GR. WEIGHT GR.	VOL. IN M ³ VOL. IN M ³	PEZZI IMBALLO OUTER BOX	FASCIA PREZZO PRICE RANGE
LAR.35.00 Bianco / White						
LAR.35. ... Filo colorato / Coloured line (*)	250	16	222	0,001	1	B23
LAR.35.C Cotto / Cotto						



Presa telefono RJ11 Telephone socket RJ11

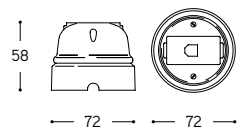

ARTICOLO ITEM	PESO GR. WEIGHT GR.	VOL. IN M ³ VOL. IN M ³	PEZZI IMBALLO OUTER BOX	FASCIA PREZZO PRICE RANGE
LAR.35.00/TEL Bianco / White				
LAR.35. .../TEL Filo colorato / Coloured line (*)	218	0,001	1	B23
LAR.35.C/TEL Cotto / Cotto				



Presa coassiale TV/SAT TV/SAT coaxial socket

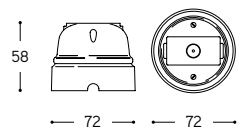

ARTICOLO ITEM	PESO GR. WEIGHT GR.	VOL. IN M ³ VOL. IN M ³	PEZZI IMBALLO OUTER BOX	FASCIA PREZZO PRICE RANGE
LAR.35.00/TV/SAT Bianco / White				
LAR.35. .../TV/SAT Filo colorato / Coloured line (*)	220	0,001	1	B23
LAR.35.C/TV/SAT Cotto / Cotto				



Scatola di derivazione Ceramic junction box

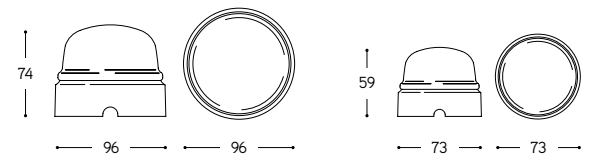

ARTICOLO ITEM	PESO GR. WEIGHT GR.	VOL. IN M ³ VOL. IN M ³	PEZZI IMBALLO OUTER BOX	FASCIA PREZZO PRICE RANGE
LAR.33.00 Grande Bianca / Big White				
LAR.33. ... Grande filo colorato / Big coloured line (*)	320	0,002	1	B19
LAR.33.C Grande Cotto / Big Cotto				
LAR.32.00 Piccola Bianca / Small White				
LAR.32. ... Piccola filo colorato / Small coloured line (*)	192	0,001	1	B13
LAR.32.C Piccola Cotto / Small Cotto				

(*) ... FR = Filo rosso / Red line
 ... FM = Filo marrone / Brown line
 ... FA = Filo ramina / Green line
 ... FB = Filo blu / Blue line
 ... FO = Filo arancio / Orange line

LINEA
Bellatrix

Serie composta da interruttore, prese e scatola di derivazione. Per tutti gli articoli della serie è prevista la variante in ceramica bianca e cotto. Gli articoli della serie sono comprensivi di frutto interno e possono essere corredati con particolari di nostra produzione della serie "Pleiadi", da ordinare a parte.

Ceramic surface mounted switch, sockets and junction box. Articles can be supplied in white ceramic or cotto ceramic. They can be combined with the "Pleiadi" accessories, to be ordered separately.

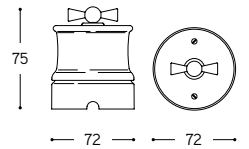
Interruttore / Deviatore
Single/two ways switch

ARTICOLO ITEM	V	A	PESO GR. WEIGHT GR.	VOL. IN M ³ VOL. IN M ³	PEZZI IMBALLO OUTER BOX	FASCIA PREZZO PRICE RANGE
LAR.140.00 Bianco / White						
LAR.140. ... Filo colorato / Coloured line (*)	250	10	234	0,001	1	B30
LAR.140.C Cotto / Cotto						



Presse bipasso Two ways socket

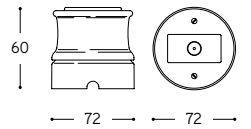

ARTICOLO ITEM	V	A	PESO GR. WEIGHT GR.	VOL. IN M ³ VOL. IN M ³	PEZZI IMBALLO OUTER BOX	FASCIA PREZZO PRICE RANGE
LAR.141.00 Bianco / White						
LAR.141. ... Filo colorato / Coloured line (*)	250	16	230	0,001	1	B23
LAR.141.C Cotto / Cotto						



Presse telefono RJ11 Telephone socket RJ11

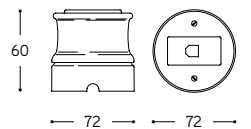

ARTICOLO ITEM	PESO GR. WEIGHT GR.	VOL. IN M ³ VOL. IN M ³	PEZZI IMBALLO OUTER BOX	FASCIA PREZZO PRICE RANGE
LAR.141.00/TEL Bianco / White				
LAR.141. .../TEL Filo colorato / Coloured line (*)	218	0,001	1	B23
LAR.141.C/TEL Cotto / Cotto				



Presse coassiale TV/SAT TV/SAT coaxial socket

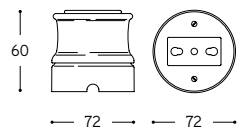

ARTICOLO ITEM	PESO GR. WEIGHT GR.	VOL. IN M ³ VOL. IN M ³	PEZZI IMBALLO OUTER BOX	FASCIA PREZZO PRICE RANGE
LAR.141.00/TV/SAT Bianco / White				
LAR.141. .../TV/SAT Filo colorato / Coloured line (*)	228	0,001	1	B23
LAR.141.C/TV/SAT Cotto / Cotto				



Scatola di derivazione Ceramic junction box

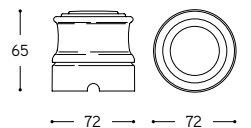

ARTICOLO ITEM	PESO GR. WEIGHT GR.	VOL. IN M ³ VOL. IN M ³	PEZZI IMBALLO OUTER BOX	FASCIA PREZZO PRICE RANGE
LAR.142.00 Bianco / White				
LAR.142. ... Filo colorato / Coloured line (*)	192	0,001	1	B13
LAR.142.C Cotto / Cotto				

(*) ... **FR** = Filo rosso / Red line
 ... **FM** = Filo marrone / Brown line
 ... **FA** = Filo ramina / Green line
 ... **FB** = Filo blu / Blue line
 ... **FO** = Filo arancio / Orange line

Art. LAR.ID9.00

LINEA
Meissa

Serie composta da interruttori, prese, una presa tipo Schuko ed una presa standard francese. Per tutti gli articoli della serie è prevista la variante in ceramica bianca e cotto. Gli articoli della serie sono comprensivi di frutto interno. La serie è stata studiata per il montaggio su scatola rotonda da incasso, compresa nell'articolo.

Ceramic surfaces mounted switches, sockets, Schuko socket and French shuttered 2 poles socket. Articles can be supplied in white ceramic or cotto ceramic. The series is designed for included flush mounting round box.

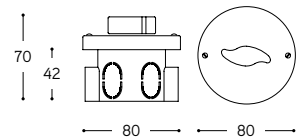
Interruttore / Deviatore
Single/two ways switch

ARTICOLO ITEM	V	A	PESO GR. WEIGHT GR	VOL. IN M ³ VOL. IN M ³	PEZZI IMBALLO OUTER BOX	FASCIA PREZZO PRICE RANGE
LAR.ID9.00 Bianco / White	250	10	144	0,001	1	B19
LAR.ID9.C Cotto / Cotto						

Per un corretto montaggio

For correct assembling

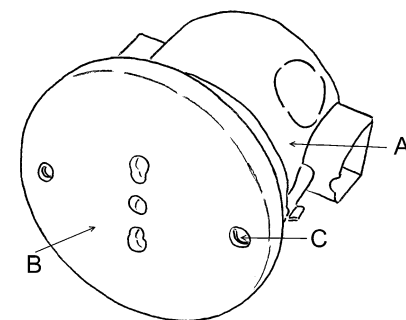

- 1 Fare eseguire l'installazione da personale qualificato.
- 2 L'articolo è composto dal coperchio in gres ceramico (B) comprensivo di presa o interruttore e da relativa scatola tonda da incasso (A).
- 3 Togliere la tensione di rete prima di procedere all'installazione dell'apparecchio.
- 4 Cementare a filo muro la scatola tonda da incasso.
- 5 Collegare i conduttori di rete alla presa o interruttore, rispettando i simboli linea, neutro e terra.
- 6 Chiudere la scatola (A) con il coperchio (B) fissandolo con le viti in dotazione nel punto (C).
- 7 Ripristinare la tensione di rete.
- 8 La nostra azienda declina ogni responsabilità per danni causati da uno scorretto utilizzo o manomissione dell'apparecchio stesso.

- 1 The installation requires a qualified electrician.
- 2 The article consists of the ceramic cover (B) with switch or socket previously fixed and the round flush mounting box (A).
- 3 Before assembling turn off the main power supply.
- 4 Cement wall-line the flush mounting box.
- 5 Connect supply leads to the switch or socket, complying with the symbols line, neutral and hearth.
- 6 Close the round flush mounting box (A) with the cover (B) and fix it with the respective screws in point (C).
- 7 Turn on the main power supply.
- 8 Our firm decline any responsibility for damage caused by incorrect use or tampering with the appliance.



Variatore luminosità
Rotary dimmer switch

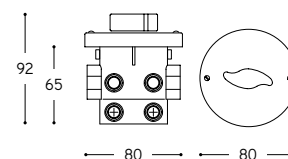

ARTICOLO ITEM	VA	PESO GR. WEIGHT GR.	VOL. IN M ³ VOL. IN M ³	PEZZI IMBALLO OUTER BOX	FASCIA PREZZO PRICE RANGE
LAR.ID9.00/DIMMER Bianco / White	400	196	0,001	1	B35
LAR.ID9.C/DIMMER Cotto / Cotto					



Presa bipasso
Two ways socket

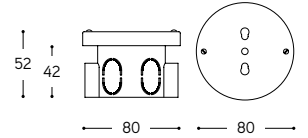

ARTICOLO ITEM	V	A	PESO GR. WEIGHT GR.	VOL. IN M ³ VOL. IN M ³	PEZZI IMBALLO OUTER BOX	FASCIA PREZZO PRICE RANGE
LAR.P13.00 Bianco / White	250	16	146	0,001	1	B8
LAR.P13.C Cotto / Cotto						



Presa telefono RJ11
Telephone socket RJ11

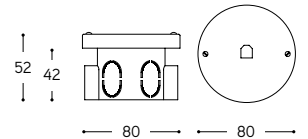

ARTICOLO ITEM	PESO GR. WEIGHT GR.	VOL. IN M ³ VOL. IN M ³	PEZZI IMBALLO OUTER BOX	FASCIA PREZZO PRICE RANGE
LAR.P13.00/TEL Bianco / White	130	0,001	1	B8
LAR.P13.C/TEL Cotto / Cotto				



Presa coassiale TV/SAT
TV/SAT coaxial socket

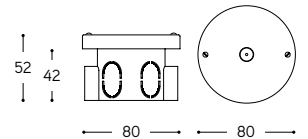

ARTICOLO ITEM	PESO GR. WEIGHT GR.	VOL. IN M ³ VOL. IN M ³	PEZZI IMBALLO OUTER BOX	FASCIA PREZZO PRICE RANGE
LAR.P13.00/TV/SAT Bianco / White	130	0,001	1	B8
LAR.P13.C/TV/SAT Cotto / Cotto				



Presa Schuko
Schuko socket

Presa Francese
French socket

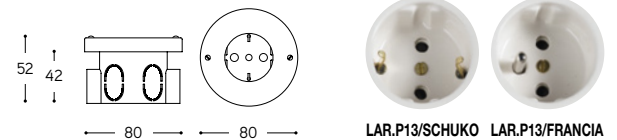

ARTICOLO ITEM	V	A	PESO GR. WEIGHT GR.	VOL. IN M ³ VOL. IN M ³	PEZZI IMBALLO OUTER BOX	FASCIA PREZZO PRICE RANGE
LAR.P13.00/SCHUKO Bianco / White	250	16	162	0,001	1	B8
LAR.P13.C/SCHUKO Cotto / Cotto						
LAR.P13.00/FRANCIA Bianco / White	250	16	162	0,001	1	B8
LAR.P13.C/FRANCIA Cotto / Cotto						

LINEA
Schengen

La linea presenta un modello di presa tipo Schuko ed un modello di presa francese 2 poli, entrambe complete di frutto interno, che possono essere ordinate nelle varianti in ceramica bianca o cotto. Si abbinano facilmente alle altre linee di nostra produzione e possono essere corredate con particolari di nostra produzione della serie "Pleiadi", da ordinare a parte.

Ceramic surface mounted Schuko socket and ceramic surface mounted French shuttered 2 poles socket, both presented in white and cotto ceramic versions. Both articles can be combined with the "Pleiadi" accessories, to be ordered separately.



Preso Schuko
Schuko socket

Preso Francese
French socket

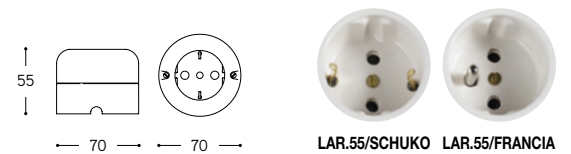

ARTICOLO ITEM	V	A	PESO GR. WEIGHT GR	VOL. IN M ³ VOL. IN M ³	PEZZI IMBALLO OUTER BOX	FASCIA PREZZO PRICE RANGE
LAR.55.00/SCHUKO Bianco / White	250	16	268	0,001	1	B30
LAR.55.C/SCHUKO Cotto / Cotto						
LAR.55.00/FRANCIA Bianco / White	250	16	268	0,001	1	B30
LAR.55.C/FRANCIA Cotto / Cotto						

LINEA
Acquario

Serie composta da interruttori, prese, una presa tipo Schuko ed una presa standard francese.

Vanno abbinati alle rispettive cornici da ordinare a parte. Le cornici, di forma ondulata o rotonda, sono previste nelle varianti in ceramica bianca, ingobbio invecchiato ed ingobbio rosso o nella variante in legno. Possono contenere da uno a tre elementi.

Tutti gli articoli di questa linea sono corredati delle rispettive scatole da incasso e frutti interni.

Ceramic surfaces mounted switches, sockets, Schuko socket and French shuttered 2 poles socket. The articles must be combined with the respective frames, to be ordered separately. Frames, round or wavy, can contains one, two or three devices and can be supplied in different versions: white ceramic, red and aged "ingobbio" or wood. The series is supplied with the respective flush mounting boxes.



Per un corretto montaggio

For correct assembling

- 1 Togliere la tensione di rete prima di procedere all'installazione dell'apparecchio. Far eseguire l'installazione da personale qualificato.
 - 2 Cementare a filo muro la scatola da incasso (A).
 - 3 Fissare alla scatola il rispettivo modulo interno (B), utilizzando le viti in dotazione (C).
 - 4 Togliere momentaneamente il pulsante (G) dalla placca in ceramica (E) degli interruttori.
 - 5 Inserire la cornice (D), inserire la placca in ceramica (E) e fissarle entrambe alla scatola di incasso utilizzando le viti in dotazione (F). Rimettere al suo posto il pulsante (G).
 - 6 Ripristinare la tensione di rete.
 - 7 L'eventuale sostituzione o manutenzione degli apparecchi è agevole in quanto è sufficiente allentare le viti, assicurandosi di aver preventivamente tolto la tensione di rete.
 - 8 La nostra azienda declina ogni responsabilità per danni causati da uno scorretto utilizzo o manomissione dell'apparecchio stesso.
-
- 1 Before beginning assembling turn off the main power supply. The installation execution requires the advice of a technician.
 - 2 Cement wall – line the flush mounting box (A).
 - 3 Fix to the box the respective interior module (B), using the respective screws (C).
 - 4 Temporary remove the button (G) from the ceramic cover (E) of switches.
 - 5 Insert the selected frame (D), insert the ceramic cover (E) fixing them to the flush mounting box with the respective screws (F). Replace the button (G).
 - 6 Turn on the main power supply.
 - 7 The possible substitution or maintenance of the equipments is easy as it's sufficient remove screws; make sure to previously turn off the main power supply.
 - 8 Our firm decline any responsibility for damage caused by incorrect use or tampering with the appliance by incorrect use or tampering with the appliance.

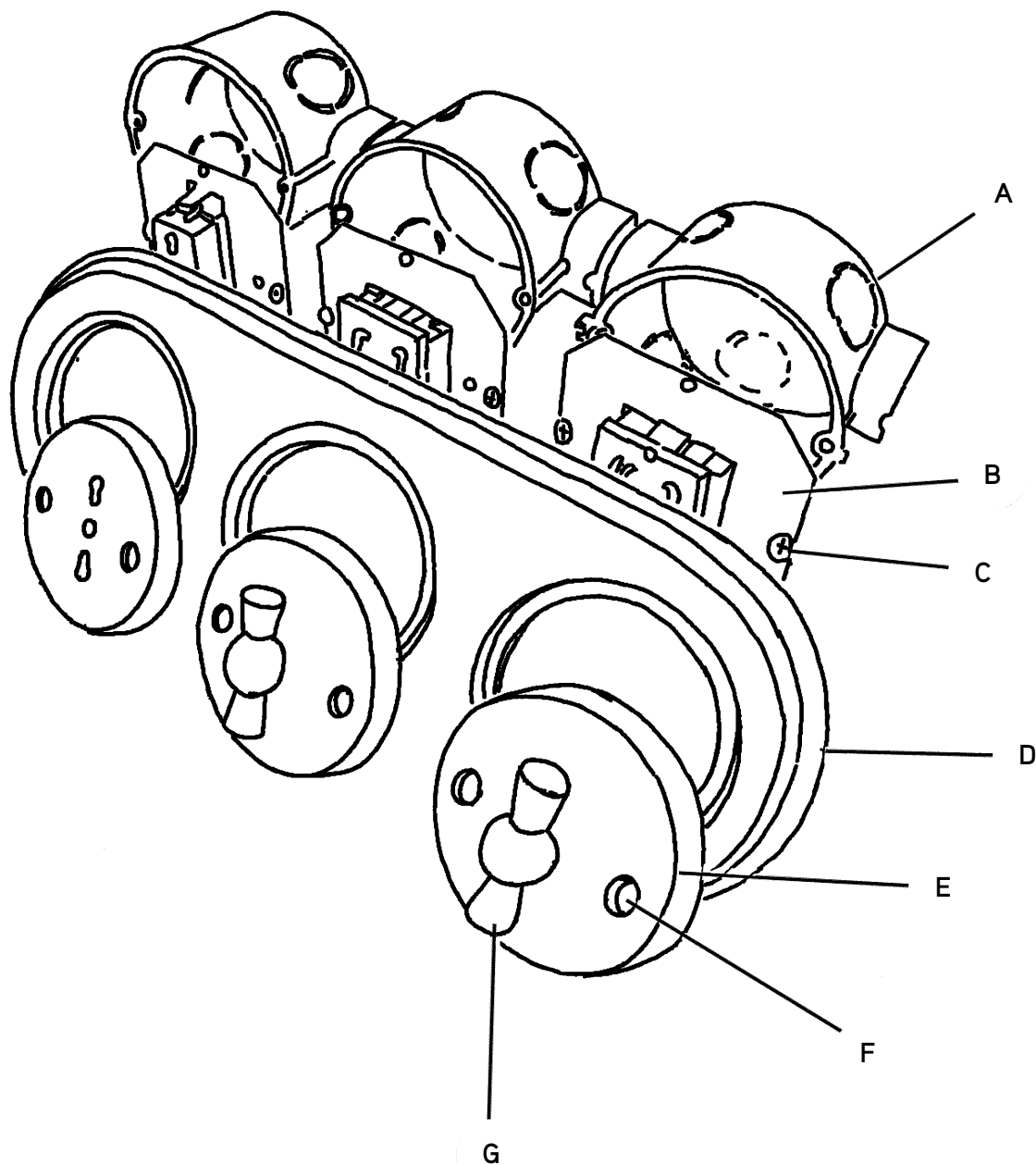



Interruttore / Deviatore Single/two ways switch

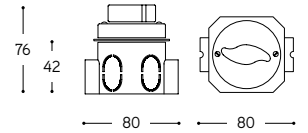

ARTICOLO ITEM	V	A	PESO GR. WEIGHT GR	VOL. IN M ³ VOL. IN M ³	PEZZI IMBALLO OUTER BOX	FASCIA PREZZO PRICE RANGE
LAR.ID1.00 Bianco / White	250	10	158	0,001	1	B19
LAR.ID1.C Cotto / Cotto						



Interruttore / Deviatore con farfallina ottone anticato Single/two ways switch with aged brass button

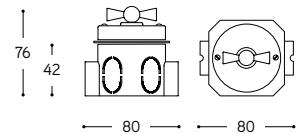

ARTICOLO ITEM	V	A	PESO GR. WEIGHT GR	VOL. IN M ³ VOL. IN M ³	PEZZI IMBALLO OUTER BOX	FASCIA PREZZO PRICE RANGE
LAR.ID2.00 Bianco / White	250	10	176	0,001	1	B19
LAR.ID2.C Cotto / Cotto						



Variatore luminosità Rotary dimmer switch

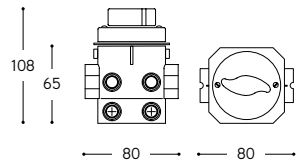

ARTICOLO ITEM	VA	PESO GR. WEIGHT GR.	VOL. IN M ³ VOL. IN M ³	PEZZI IMBALLO OUTER BOX	FASCIA PREZZO PRICE RANGE
LAR.ID1.00/DIMMER Bianco / White	400	206	0,001	1	B35
LAR.ID1.C/DIMMER Cotto / Cotto					



Presà bipasso Two ways socket

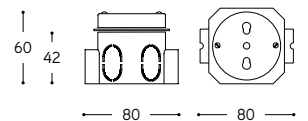

ARTICOLO ITEM	V	A	PESO GR. WEIGHT GR	VOL. IN M ³ VOL. IN M ³	PEZZI IMBALLO OUTER BOX	FASCIA PREZZO PRICE RANGE
LAR.P1.00 Bianco / White	250	16	148	0,001	1	B8
LAR.P1.C Cotto / Cotto						



Presa Internet RJ45
Internet socket

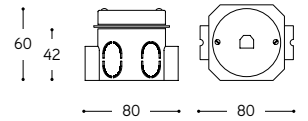

ARTICOLO ITEM	PESO GR. WEIGHT GR.	VOL. IN M ³ VOL. IN M ³	PEZZI IMBALLO OUTER BOX	FASCIA PREZZO PRICE RANGE
LAR.P1.00/INTE Bianco / White	148	0,001	1	B33
LAR.P1.C/INTE Cotto / Cotto				



Presa telefono RJ11
Telephone socket RJ11

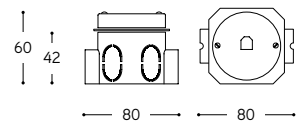

ARTICOLO ITEM	PESO GR. WEIGHT GR.	VOL. IN M ³ VOL. IN M ³	PEZZI IMBALLO OUTER BOX	FASCIA PREZZO PRICE RANGE
LAR.P1.00/TEL Bianco / White	142	0,001	1	B8
LAR.P1.C/TEL Cotto / Cotto				



Presa coassiale TV/SAT
TV/SAT coaxial socket

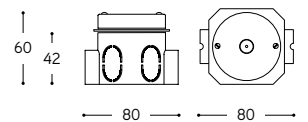

ARTICOLO ITEM	PESO GR. WEIGHT GR.	VOL. IN M ³ VOL. IN M ³	PEZZI IMBALLO OUTER BOX	FASCIA PREZZO PRICE RANGE
LAR.P1.00/TV/SAT Bianco / White	142	0,001	1	B8
LAR.P1.C/TV/SAT Cotto / Cotto				



Presa Schuko
Schuko socket

Presa Francese
French socket

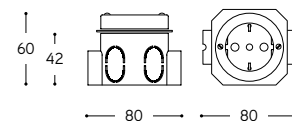

ARTICOLO ITEM	V	A	PESO GR. WEIGHT GR.	VOL. IN M ³ VOL. IN M ³	PEZZI IMBALLO OUTER BOX	FASCIA PREZZO PRICE RANGE
LAR.P1.00/SCHUKO Bianco / White	250	16	174	0,001	1	B8
LAR.P1.C/SCHUKO Cotto / Cotto						
LAR.P1.00/FRANCIA Bianco / White	250	16	174	0,001	1	B8
LAR.P1.C/FRANCIA Cotto / Cotto						



Cornice ondulata in ceramica
1 posizione
Ceramic wavy frame
1 position

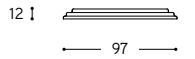
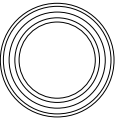

ARTICOLO ITEM	PESO GR. WEIGHT GR.	VOL. IN M ³ VOL. IN M ³	PEZZI IMBALLO OUTER BOX	FASCIA PREZZO PRICE RANGE
OND1 Bianco / White				B12
OND7 Ingobbio invecchiato / Aged "Ingobbio"	120	0,002	1	B14
OND10 Ingobbio rosso / Red "Ingobbio"				B14



Cornice ondulata in ceramica
2 posizioni
Ceramic wavy frame
2 positions

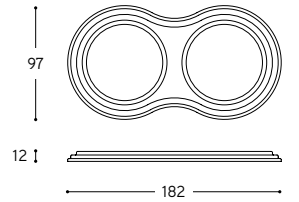

ARTICOLO ITEM	PESO GR. WEIGHT GR.	VOL. IN M ³ VOL. IN M ³	PEZZI IMBALLO OUTER BOX	FASCIA PREZZO PRICE RANGE
OND2 Bianco / White				B19
OND8 Ingobbio invecchiato / Aged "Ingobbio"	260	0,004	1	B21
OND11 Ingobbio rosso / Red "Ingobbio"				B21



Cornice ondulata in ceramica
3 posizioni
Ceramic wavy frame
3 positions

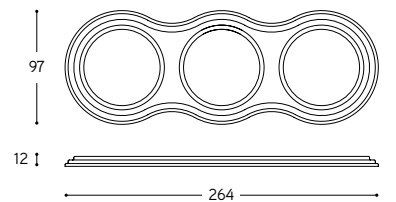

ARTICOLO ITEM	PESO GR. WEIGHT GR.	VOL. IN M ³ VOL. IN M ³	PEZZI IMBALLO OUTER BOX	FASCIA PREZZO PRICE RANGE
OND3 Bianco / White				B23
OND9 Ingobbio invecchiato / Aged "Ingobbio"	356	0,004	1	B30
OND12 Ingobbio rosso / Red "Ingobbio"				B30





Cornice ondulata in legno
1 posizione
Wood wavy frame
1 position

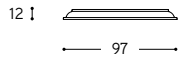
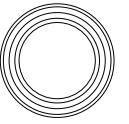

ARTICOLO ITEM	PESO GR. WEIGHT GR.	VOL. IN M ³ VOL. IN M ³	PEZZI IMBALLO OUTER BOX	FASCIA PREZZO PRICE RANGE
OND13 Finitura ciliegio / Cherry finish	74	0,002	1	B6



Cornice ondulata in legno
2 posizioni
Wood wavy frame
2 positions

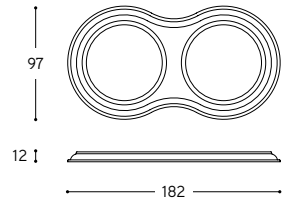

ARTICOLO ITEM	PESO GR. WEIGHT GR.	VOL. IN M ³ VOL. IN M ³	PEZZI IMBALLO OUTER BOX	FASCIA PREZZO PRICE RANGE
OND14 Finitura ciliegio / Cherry finish	182	0,004	1	B10



Cornice ondulata in legno
3 posizioni
Wood wavy frame
3 positions

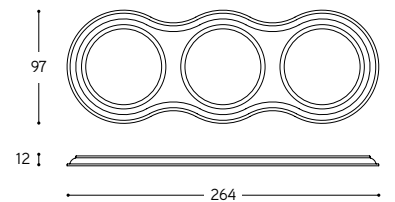

ARTICOLO ITEM	PESO GR. WEIGHT GR.	VOL. IN M ³ VOL. IN M ³	PEZZI IMBALLO OUTER BOX	FASCIA PREZZO PRICE RANGE
OND15 Finitura ciliegio / Cherry finish	216	0,004	1	B14





Cornice tonda in ceramica
1 posizione
Ceramic round frame
1 position

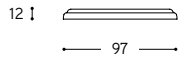
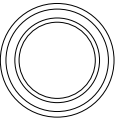

ARTICOLO ITEM	PESO GR. WEIGHT GR.	VOL. IN M ³ VOL. IN M ³	PEZZI IMBALLO OUTER BOX	FASCIA PREZZO PRICE RANGE
RO1 Bianco / White				B12
RO7 Ingobbio invecchiato / Aged "Ingobbio"	126	0,002	1	B14
RO10 Ingobbio rosso / Red "Ingobbio"				B14



Cornice tonda in ceramica
2 posizioni
Ceramic round frame
2 positions

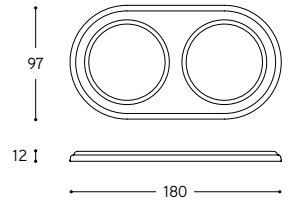

ARTICOLO ITEM	PESO GR. WEIGHT GR.	VOL. IN M ³ VOL. IN M ³	PEZZI IMBALLO OUTER BOX	FASCIA PREZZO PRICE RANGE
RO2 Bianco / White				B19
RO8 Ingobbio invecchiato / Aged "Ingobbio"	304	0,004	1	B21
RO11 Ingobbio rosso / Red "Ingobbio"				B21



Cornice tonda in ceramica
3 posizioni
Ceramic round frame
3 positions

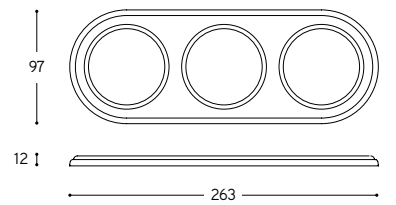

ARTICOLO ITEM	PESO GR. WEIGHT GR.	VOL. IN M ³ VOL. IN M ³	PEZZI IMBALLO OUTER BOX	FASCIA PREZZO PRICE RANGE
RO3 Bianco / White				B23
RO9 Ingobbio invecchiato / Aged "Ingobbio"	408	0,004	1	B30
RO12 Ingobbio rosso / Red "Ingobbio"				B30





Cornice tonda in legno
1 posizione
Wood round frame
1 position

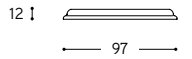
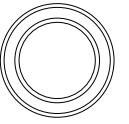

ARTICOLO ITEM	PESO GR. WEIGHT GR.	VOL. IN M ³ VOL. IN M ³	PEZZI IMBALLO OUTER BOX	FASCIA PREZZO PRICE RANGE
RO13 Finitura ciliegio / Cherry finish	74	0,002	1	B6



Cornice tonda in legno
2 posizioni
Wood round frame
2 positions

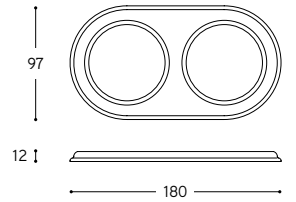

ARTICOLO ITEM	PESO GR. WEIGHT GR.	VOL. IN M ³ VOL. IN M ³	PEZZI IMBALLO OUTER BOX	FASCIA PREZZO PRICE RANGE
RO14 Finitura ciliegio / Cherry finish	184	0,004	1	B10



Cornice tonda in legno
3 posizioni
Wood round frame
3 positions

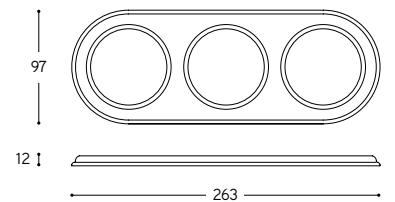

ARTICOLO ITEM	PESO GR. WEIGHT GR.	VOL. IN M ³ VOL. IN M ³	PEZZI IMBALLO OUTER BOX	FASCIA PREZZO PRICE RANGE
RO15 Finitura ciliegio / Cherry finish	226	0,004	1	B14

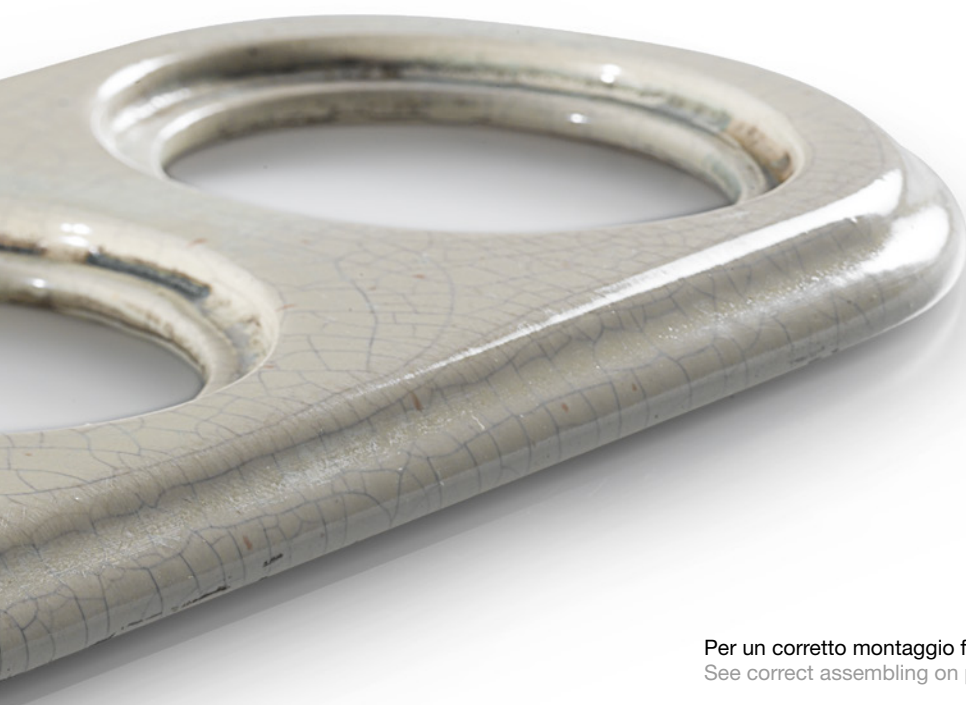

Art. LAR.INT.FB.03
Art. LAR.134.A

Art. LAR.131.00
Art. LAR.138.06

LINEA Mimosa

Serie composta da interruttore/deviatore, scatola di derivazione e custodie da parete per prese o interruttori. Quest'ultimo articolo è comprensivo di frutto interno. I materiali utilizzati sono la ceramica bianca, la ceramica decorata con filo colorato o la ceramica - cotto. Gli articoli della serie possono essere corredati con particolari di nostra produzione della serie "Pleiadi", da ordinare a parte.

Ceramic surface cases for socket and switches, ceramic surface mounted switch and junction box. Articles can be supplied in different versions: white ceramic, coloured line ceramic or cotto ceramic. They can be combined with the "Pleiadi" accessories, to be ordered separately.



Interruttore / Deviatore Single/two ways switch

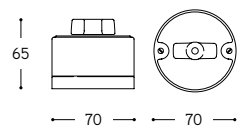

ARTICOLO ITEM	V	A	PESO GR. WEIGHT GR.	VOL. IN M ³ VOL. IN M ³	PEZZI IMBALLO OUTER BOX	FASCIA PREZZO PRICE RANGE
LAR.INT.00.01 Bianco / White						
LAR.INT.01 Filo colorato / Coloured line (*)	250	10	236	0,001	1	B21
LAR.INT.C.01 Cotto / Cotto						



Interruttore / Deviatore Single/two ways switch

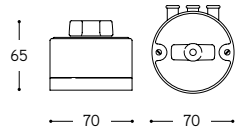

ARTICOLO ITEM	V	A	PESO GR. WEIGHT GR.	VOL. IN M ³ VOL. IN M ³	PEZZI IMBALLO OUTER BOX	FASCIA PREZZO PRICE RANGE
LAR.INT.00.03 Bianco / White						
LAR.INT.03 Filo colorato / Coloured line (*)	250	10	238	0,001	1	B23
LAR.INT.C.03 Cotto / Cotto						



Custodia da parete per prese ed interruttori (**) Surface cases for socket and switches (**)

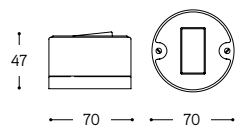

ARTICOLO ITEM	V	A	PESO GR. WEIGHT GR.	VOL. IN M ³ VOL. IN M ³	PEZZI IMBALLO OUTER BOX	FASCIA PREZZO PRICE RANGE
LAR.PRE.00.01 Bianco / White						
LAR.PRE.01 Filo colorato / Coloured line (*)	250	16	218	0,001	1	B19
LAR.PRE.C.01 Cotto / Cotto						



Custodia da parete per prese ed interruttori (**) Surface cases for socket and switches (**)

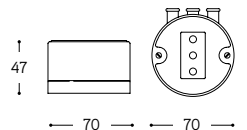

ARTICOLO ITEM	V	A	PESO GR. WEIGHT GR.	VOL. IN M ³ VOL. IN M ³	PEZZI IMBALLO OUTER BOX	FASCIA PREZZO PRICE RANGE
LAR.PRE.00.03 Bianco / White						
LAR.PRE.03 Filo colorato / Coloured line (*)	250	16	222	0,001	1	B21
LAR.PRE.C.03 Cotto / Cotto						



Scatola di derivazione Ceramic junction box

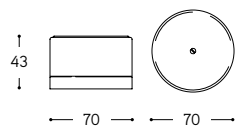

ARTICOLO ITEM	V	A	PESO GR. WEIGHT GR.	VOL. IN M ³ VOL. IN M ³	PEZZI IMBALLO OUTER BOX	FASCIA PREZZO PRICE RANGE
LAR.DER.00						
LAR.DER. ... Filo colorato / Coloured line (*)			200	0,001	1	B19
LAR.DER.C Cotto / Cotto						

(**) Gli interruttori/prese della serie LAR.PRE sono predisposti per apparecchi della serie VIMAR 8000 che non vengono forniti con l'articolo
Switches/socket of LAR.PRE series are arranged for devices VIMAR 8000 series that are not included in the article

I Filo colorati sono illustrati a pag. 184
See Coloured lines on page 184

(*) ... FR = Filo rosso / Red line
... FM = Filo marrone / Brown line
... FA = Filo ramina / Green line
... FB = Filo blu / Blue line
... FO = Filo arancio / Orange line

LINEA Pleiadi

Questa serie di accessori integra l'impianto a treccia ed è composta da rosoni in ceramica, contro basi in legno, passafilo lineari, passafilo a curva retta o tonda, isolatori singoli a due misure, isolatori doppi, treccia cotone e placche in ceramica.

L'articolo "placca" è solo predisposto per moduli delle serie "MAGIC o MATIX B.TICINO", "VIMAR IDEA" e "VIMAR PLANA" che quindi non vengono forniti con l'articolo ordinato.

I materiali utilizzati sono la ceramica bianca, la ceramica decorata con filo colorato e la ceramica-cotto.

This series of accessories integrates the system with cotton braid and is composed of ceiling roses, wood cover for ceramic bases, wire guide in white or cotto ceramic, single or double insulators, twisted cloth cord and ceramic plates.

The article "plate" is only arranged for modules of the series "MAGIC or MATIX B.TICINO", "VIMAR IDEA" and "VIMAR PLANA" that are not provided with the item ordered.

The materials used are white or cotto ceramic and decorated ceramic with colored line.





Passafilo in ceramica Wire guide in ceramic

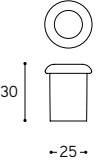

ARTICOLO ITEM	PESO GR. WEIGHT GR	VOL. IN M ³ VOL. IN M ³	PEZZI IMBALLO OUTER BOX	FASCIA PREZZO PRICE RANGE
LAR.133.00 Bianco / White	278	0,001	18	B33
LAR.133.C Cotto / Cotto				



Treccia in cotone Cotton braid

Pezzo singolo / Single pc

ARTICOLO ITEM	SEZ. IN MM SECT. IN MM	PESO GR. WEIGHT GR.	VOL. IN M ³ VOL. IN M ³	PEZZI IMBALLO OUTER BOX	FASCIA PREZZO PRICE RANGE
LAR.138.01/MT. Bianco / White					
LAR.138.03/MT. Marrone / Brown	3 x 0,75	103	0,001	1 mt.	B4
LAR.138.05/MT. Avorio / Ivory					
LAR.138.07/MT. Oro / Gold					
LAR.138.09/MT. Bianco / White					
LAR.138.10/MT. Marrone / Brown	3 x 1,50	138	0,001	1 mt.	B5
LAR.138.11/MT. Avorio / Ivory					
LAR.138.12/MT. Oro / Gold					
LAR.138.02/MT. Bianco / White					
LAR.138.04/MT. Marrone / Brown	3 x 2,50	168	0,001	1 mt.	B9
LAR.138.06/MT. Avorio / Ivory					
LAR.138.08/MT. Oro / Gold					

Confezione 50 mt / 50 m roll

ARTICOLO ITEM	SEZ. IN MM SECT. IN MM	PESO GR. WEIGHT GR.	VOL. IN M ³ VOL. IN M ³	PEZZI IMBALLO OUTER BOX	FASCIA PREZZO PRICE RANGE
LAR.138.01/CONF. Bianco / White					
LAR.138.03/CONF. Marrone / Brown	3 x 0,75	2.720	0,02	1 matassa da 50 mt. 50 m roll	B66
LAR.138.05/CONF. Avorio / Ivory					
LAR.138.07/CONF. Oro / Gold					
LAR.138.09/CONF. Bianco / White					
LAR.138.10/CONF. Marrone / Brown	3 x 1,50	4.520	0,02	1 matassa da 50 mt. 50 m roll	B78
LAR.138.11/CONF. Avorio / Ivory					
LAR.138.12/CONF. Oro / Gold					
LAR.138.02/CONF. Bianco / White					
LAR.138.04/CONF. Marrone / Brown	3 x 2,50	6.000	0,02	1 matassa da 50 mt. 50 m roll	B91
LAR.138.06/CONF. Avorio / Ivory					
LAR.138.08/CONF. Oro / Gold					



Isolatore piccolo / Little insulator

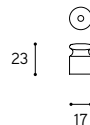

Pezzo singolo / Single pc

ARTICOLO ITEM	PESO GR. WEIGHT GR	VOL. IN M ³ VOL. IN M ³	PEZZI IMBALLO OUTER BOX	FASCIA PREZZO PRICE RANGE
LAR.131.00/ISO Bianco / White	8	0,001	1	B3
LAR.131.C/ISO Cotto / Cotto				

Confezione 50 pezzi / 50 pack

ARTICOLO ITEM	PESO GR. WEIGHT GR	VOL. IN M ³ VOL. IN M ³	PEZZI IMBALLO OUTER BOX	FASCIA PREZZO PRICE RANGE
LAR.131.00/CONF. Bianco / White	548	0,004	50	B43
LAR.131.C/CONF. Cotto / Cotto				



Isolatore grande Big insulator



ARTICOLO ITEM	PESO GR. WEIGHT GR	VOL. IN M ³ VOL. IN M ³	PEZZI IMBALLO OUTER BOX	FASCIA PREZZO PRICE RANGE
LAR.130.00 Bianco / White	480	0,001	10	B33
LAR.130.C Cotto / Cotto				



Isolatore doppio Double insulator

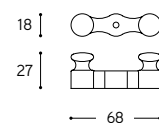

ARTICOLO ITEM	PESO GR. WEIGHT GR	VOL. IN M ³ VOL. IN M ³	PEZZI IMBALLO OUTER BOX	FASCIA PREZZO PRICE RANGE
LAR.132.00 Bianco / White	558	0,001	15	B43
LAR.132.C Cotto / Cotto				



ISOLATORE DOPPIO
DOUBLE INSULATOR



Curva retta Square wire guide

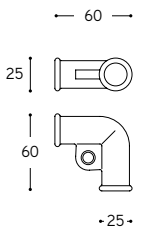

ARTICOLO ITEM	PESO GR. WEIGHT GR	VOL. IN M ³ VOL. IN M ³	PEZZI IMBALLO OUTER BOX	FASCIA PREZZO PRICE RANGE
LAR.116.00 Bianco / White	340	0,001	6	B37
LAR.116.C Cotto / Cotto				



Curva tonda piccola Little round wire guide

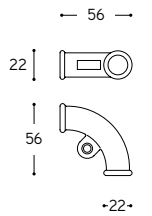

ARTICOLO ITEM	PESO GR. WEIGHT GR	VOL. IN M ³ VOL. IN M ³	PEZZI IMBALLO OUTER BOX	FASCIA PREZZO PRICE RANGE
LAR.120.00 Bianco / White	320	0,001	8	B37
LAR.120.C Cotto / Cotto				



Curva tonda grande Big round wire guide

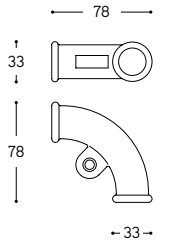

ARTICOLO ITEM	PESO GR. WEIGHT GR	VOL. IN M ³ VOL. IN M ³	PEZZI IMBALLO OUTER BOX	FASCIA PREZZO PRICE RANGE
LAR.126.00 Bianco / White	414	0,002	4	B33
LAR.126.C Cotto / Cotto				



CURVA RETTA
WIRE GUIDE



Rosette in legno Wood canopies

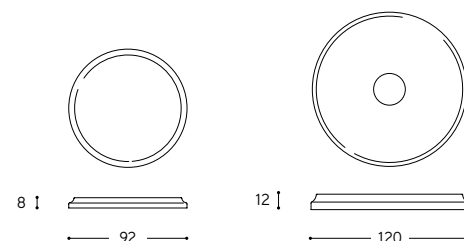

ARTICOLO ITEM	PESO GR. WEIGHT GR	VOL. IN M ³ VOL. IN M ³	PEZZI IMBALLO OUTER BOX	FASCIA PREZZO PRICE RANGE
LAR.134.A Piccola / Little	248	0,001	4	B13
LAR.134.B Grande / Big	414	0,002	4	B13



Rosone per decentramento Roses

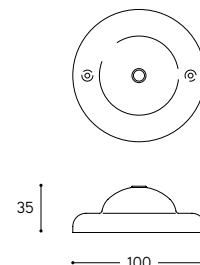

ARTICOLO ITEM	PESO GR. WEIGHT GR.	VOL. IN M ³ VOL. IN M ³	PEZZI IMBALLO OUTER BOX	FASCIA PREZZO PRICE RANGE
LAR.02.00 Bianco / White				
LAR.02. ... Filo colorato / Coloured line (*)	166	0,002	1	B8
LAR.02.C Cotto / Cotto				



Rosone per decentramento Roses

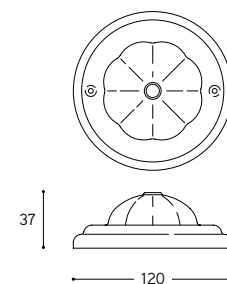

ARTICOLO ITEM	PESO GR. WEIGHT GR.	VOL. IN M ³ VOL. IN M ³	PEZZI IMBALLO OUTER BOX	FASCIA PREZZO PRICE RANGE
LAR.05.00 Bianco / White				
LAR.05. ... Filo colorato / Coloured line (*)	206	0,002	1	B8
LAR.05.C Cotto / Cotto				

(*) ... **FR** = Filo rosso / Red line
 ... **FM** = Filo marrone / Brown line
 ... **FA** = Filo ramina / Green line
 ... **FB** = Filo blu / Blue line
 ... **FO** = Filo arancio / Orange line

Per un corretto montaggio fare riferimento alle istruzioni presenti a pag. 182-183
 See correct assembling on page 182-183

I Fili colorati sono illustrati a pag. 184
 See Coloured lines on page 184



Design Studio Leonardo Emiliozzi

Placca 3 posti
per moduli B. Ticino MATIX (**)
Three - opening plate
for B. Ticino MATIX modules (**)

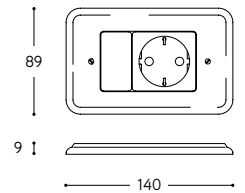

ARTICOLO ITEM	PESO GR. WEIGHT GR.	VOL. IN M ³ VOL. IN M ³	PEZZI IMBALLO OUTER BOX	FASCIA PREZZO PRICE RANGE
1PMTT.00 Bianco / White	200	0,002	1	B10
1PMTT. ... Filo colorato / Coloured line (*)				



Design Studio Leonardo Emiliozzi

Placca per modulo Schuko
B. Ticino MATIX (**)
Plate for Schuko
B. Ticino MATIX module (**)

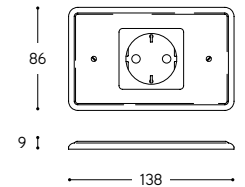

ARTICOLO ITEM	PESO GR. WEIGHT GR.	VOL. IN M ³ VOL. IN M ³	PEZZI IMBALLO OUTER BOX	FASCIA PREZZO PRICE RANGE
1PM.S.00 Bianco / White	200	0,002	1	B10
1PM.S. ... Filo colorato / Coloured line (*)				
1PM.S.C Cotto / Cotto				



Placca 3 posti
per moduli Vimar IDEA (**)
Three - opening plate
for Vimar IDEA modules (**)

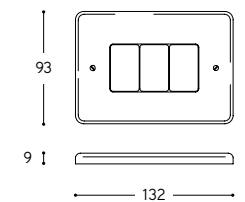

ARTICOLO ITEM	PESO GR. WEIGHT GR.	VOL. IN M ³ VOL. IN M ³	PEZZI IMBALLO OUTER BOX	FASCIA PREZZO PRICE RANGE
1PMIDEA.00 Bianco / White	220	0,002	1	B10
1PMIDEA. ... Filo colorato / Coloured line (*)				



Placca 3 posti
per moduli Vimar PLANA (**)
Three - opening plate
for Vimar PLANA modules (**)

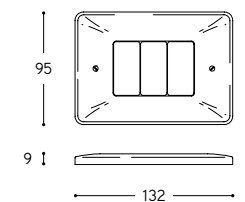

ARTICOLO ITEM	PESO GR. WEIGHT GR.	VOL. IN M ³ VOL. IN M ³	PEZZI IMBALLO OUTER BOX	FASCIA PREZZO PRICE RANGE
1PMPLANA.00 Bianco / White	220	0,002	1	B10

(*) ... **FR** = Filo rosso / Red line
 ... **FM** = Filo marrone / Brown line
 ... **FA** = Filo ramina / Green line
 ... **FB** = Filo blu / Blue line
 ... **FO** = Filo arancio / Orange line

(**) **I moduli B. Ticino MATIX, Vimar IDEA e Vimar PLANA non sono compresi nell'articolo**
B. Ticino MATIX modules, Vimar IDEA and Vimar PLANA modules are not provided with the article

I Fili colorati sono illustrati a pag. 184
 See Coloured lines on page 184



Design Studio Leonardo Emiliozzi

Placca 1 posto
per modulo B. Ticino MAGIC (**)
One - opening plate
for B. Ticino MAGIC module (**)

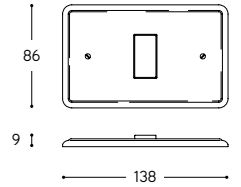

ARTICOLO ITEM	PESO GR. WEIGHT GR.	VOL. IN M ³ VOL. IN M ³	PEZZI IMBALLO OUTER BOX	FASCIA PREZZO PRICE RANGE
1PM1.00 Bianco / White				
1PM1. ... Filo colorato / Coloured line (*)	200	0,002	1	B10
1PM1.C Cotto / Cotto				



Design Studio Leonardo Emiliozzi

Placca 2 posti
per moduli B. Ticino MAGIC (**)
Two - opening plate
for B. Ticino MAGIC modules (**)

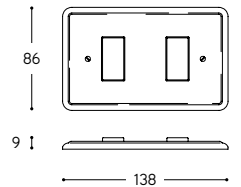

ARTICOLO ITEM	PESO GR. WEIGHT GR.	VOL. IN M ³ VOL. IN M ³	PEZZI IMBALLO OUTER BOX	FASCIA PREZZO PRICE RANGE
1PM2.00 Bianco / White				
1PM2. ... Filo colorato / Coloured line (*)	195	0,002	1	B10
1PM2.C Cotto / Cotto				



Design Studio Leonardo Emiliozzi

Placca 3 posti
per moduli B. Ticino MAGIC (**)
Three - opening plate
for B. Ticino MAGIC modules (**)

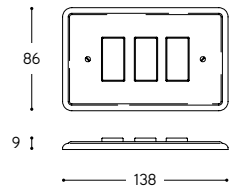

ARTICOLO ITEM	PESO GR. WEIGHT GR.	VOL. IN M ³ VOL. IN M ³	PEZZI IMBALLO OUTER BOX	FASCIA PREZZO PRICE RANGE
1PM3.00 Bianco / White				
1PM3. ... Filo colorato / Coloured line (*)	190	0,002	1	B10
1PM3.C Cotto / Cotto				



Design Studio Leonardo Emiliozzi

Placca 4 posti
per moduli B. Ticino MAGIC (**)
Four - opening plate
for B. Ticino MAGIC modules (**)

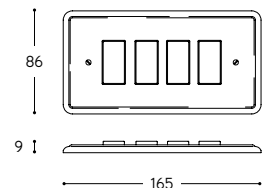

ARTICOLO ITEM	PESO GR. WEIGHT GR.	VOL. IN M ³ VOL. IN M ³	PEZZI IMBALLO OUTER BOX	FASCIA PREZZO PRICE RANGE
1PM4.00 Bianco / White				
1PM4. ... Filo colorato / Coloured line (*)	220	0,002	1	B13
1PM4.C Cotto / Cotto				



Placca 5 posti
per moduli B. Ticino MAGIC (**)
Five - opening plate
for B. Ticino MAGIC modules (**)

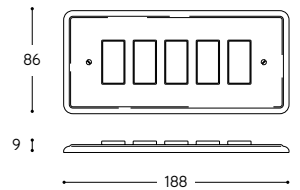

ARTICOLO ITEM	PESO GR. WEIGHT GR.	VOL. IN M ³ VOL. IN M ³	PEZZI IMBALLO OUTER BOX	FASCIA PREZZO PRICE RANGE
1PM5.00 Bianco / White				
1PM5. ... Filo colorato / Coloured line (*)	250	0,004	1	B13
1PM5.C Cotto / Cotto				

(*) ... **FR** = Filo rosso / Red line
 ... **FM** = Filo marrone / Brown line
 ... **FA** = Filo ramina / Green line
 ... **FB** = Filo blu / Blue line
 ... **FO** = Filo arancio / Orange line

(**) **I moduli B. Ticino MAGIC non sono compresi nell'articolo**
B. Ticino MAGIC modules are not provided with the article

I Fili colorati sono illustrati a pag. 184
 See Coloured lines on page 184



Design Studio Leonardo Emiliozzi

Placca 1 posto
per modulo B. Ticino MAGIC (**)
One - opening plate
for B. Ticino MAGIC module (**)

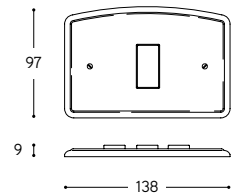

ARTICOLO ITEM	PESO GR. WEIGHT GR.	VOL. IN M ³ VOL. IN M ³	PEZZI IMBALLO OUTER BOX	FASCIA PREZZO PRICE RANGE
2PM1.00 Bianco / White				
2PM1. ... Filo colorato / Coloured line (*)	215	0,002	1	B10
2PM1.C Cotto / Cotto				



Design Studio Leonardo Emiliozzi

Placca 2 posti
per moduli B. Ticino MAGIC (**)
Two - opening plate
for B. Ticino MAGIC modules (**)

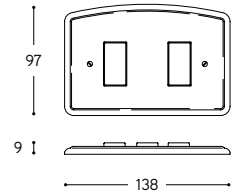

ARTICOLO ITEM	PESO GR. WEIGHT GR.	VOL. IN M ³ VOL. IN M ³	PEZZI IMBALLO OUTER BOX	FASCIA PREZZO PRICE RANGE
2PM2.00 Bianco / White				
2PM2. ... Filo colorato / Coloured line (*)	220	0,002	1	B10
2PM2.C Cotto / Cotto				



Design Studio Leonardo Emiliozzi

Placca 3 posti
per moduli B. Ticino MAGIC (**)
Three - opening plate
for B. Ticino MAGIC modules (**)

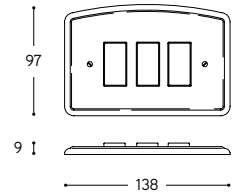

ARTICOLO ITEM	PESO GR. WEIGHT GR.	VOL. IN M ³ VOL. IN M ³	PEZZI IMBALLO OUTER BOX	FASCIA PREZZO PRICE RANGE
2PM3.00 Bianco / White				
2PM3. ... Filo colorato / Coloured line (*)	205	0,002	1	B10
2PM3.C Cotto / Cotto				

(*) ... **FR** = Filo rosso / Red line
 ... **FM** = Filo marrone / Brown line
 ... **FA** = Filo ramina / Green line
 ... **FB** = Filo blu / Blue line
 ... **FO** = Filo arancio / Orange line

(**) **I moduli B. Ticino MAGIC non sono compresi nell'articolo**
B. Ticino MAGIC modules are not provided with the article

I Fili colorati sono illustrati a pag. 184
 See Coloured lines on page 184



Design Studio Leonardo Emiliozzi

Placca 1 posto
per modulo B. Ticino MAGIC (**)
One - opening plate
for B. Ticino MAGIC module (**)

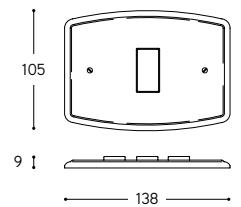

ARTICOLO ITEM	PESO GR. WEIGHT GR.	VOL. IN M ³ VOL. IN M ³	PEZZI IMBALLO OUTER BOX	FASCIA PREZZO PRICE RANGE
3PM1.00 Bianco / White				
3PM1. ... Filo colorato / Coloured line (*)	235	0,002	1	B10
3PM1.C Cotto / Cotto				



Design Studio Leonardo Emiliozzi

Placca 2 posti
per moduli B. Ticino MAGIC (**)
Two - opening plate
for B. Ticino MAGIC modules (**)

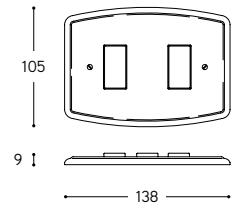

ARTICOLO ITEM	PESO GR. WEIGHT GR.	VOL. IN M ³ VOL. IN M ³	PEZZI IMBALLO OUTER BOX	FASCIA PREZZO PRICE RANGE
3PM2.00 Bianco / White				
3PM2. ... Filo colorato / Coloured line (*)	225	0,002	1	B10
3PM2.C Cotto / Cotto				



Design Studio Leonardo Emiliozzi

Placca 3 posti
per moduli B. Ticino MAGIC (**)
Three - opening plate
for B. Ticino MAGIC modules (**)

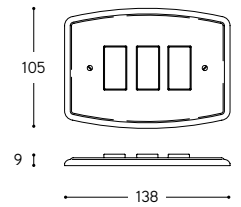

ARTICOLO ITEM	PESO GR. WEIGHT GR.	VOL. IN M ³ VOL. IN M ³	PEZZI IMBALLO OUTER BOX	FASCIA PREZZO PRICE RANGE
3PM3.00 Bianco / White				
3PM3. ... Filo colorato / Coloured line (*)	220	0,002	1	B10
3PM3.C Cotto / Cotto				

(*) ... **FR** = Filo rosso / Red line
 ... **FM** = Filo marrone / Brown line
 ... **FA** = Filo ramina / Green line
 ... **FB** = Filo blu / Blue line
 ... **FO** = Filo arancio / Orange line

(**) **I moduli B. Ticino MAGIC non sono compresi nell'articolo**
B. Ticino MAGIC modules are not provided with the article

I Fili colorati sono illustrati a pag. 184
 See Coloured lines on page 184

Per un corretto montaggio For correct assembling

- 1 Consigliamo di mettere gli isolatori ad una distanza di 30/35 cm l'uno dall'altro segnando sul muro il loro corretto posizionamento
- 1 It is advisable to place the isolators at a distance of 30/35 cm from each other, marking their correct position on the wall.

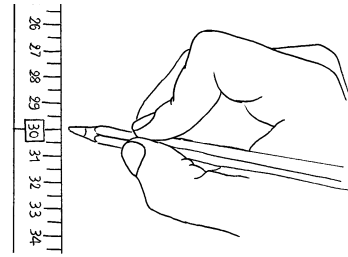

- 2 Assicurarsi che a 3 cm dall'entrata della treccia sugli accessori da installare, ci sia lo spazio per mettere un isolatore fig. A e fig. B
- 2 Ensure that there is space to fit the isolator at 3 cm from the entrance of the braid on the accessories being installed, fig. A and fig. B

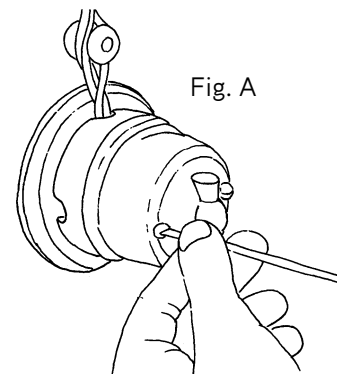

Fig. A

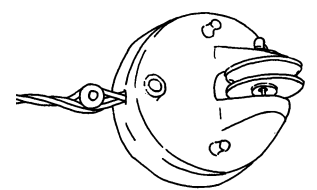
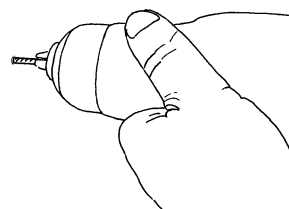
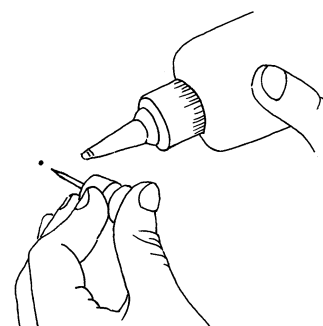

Fig. B

- 3 Forare la parete con una punta da trapano di mm 2.
- 3 Drill the wall with a 2 mm drill bit.



- 4 Interporre una goccia di colla vinilica o attack sulla punta del chiodo in dotazione, precedentemente già inserito nell'isolatore.
- 4 Place a drop of vinyl glue or super glue on the tip of the supplied nail after passing it through the insulator.



- 5 Fissare l'isolatore sulla parete; prestare attenzione a non danneggiare la ceramica con il martello.
- 5 Fix the isolator to the wall taking care not to damage the ceramic part with the hammer.

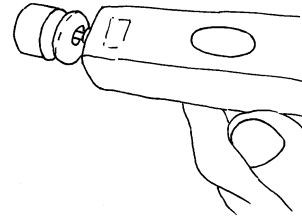

- 6 Procedere ora al posizionamento della treccia.
Per una buona tensione: inserire la treccia nel primo isolatore, avvolgerla su se stessa in senso orario, posizionarla sul secondo isolatore e procedere così di seguito fino a quando si arriva sull'accessorio da collegare.
- 6 The braid can now be positioned.
To get the correct tension: pass the braid through the first isolator, winding it around itself in a clockwise direction, pass it through the second isolator and so on until it reaches the accessory that is being connected.

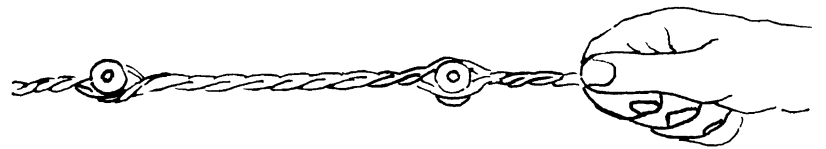

- 7 Per deviazioni o curve possono essere utilizzati gli accessori di nostra produzione (passabili ad angolo retto o curvo). fig. F in alternativa collocare due isolatori ad angolo retto, ad una distanza di 5/7 cm l'uno dall'altro come da fig. G
- 7 If there are any branches or curves, our original accessories should be used (for right-angled or curved corners), fig. F alternatively, place two isolators at right angles at a distance of 5/7 cm from each other, as shown in fig. G

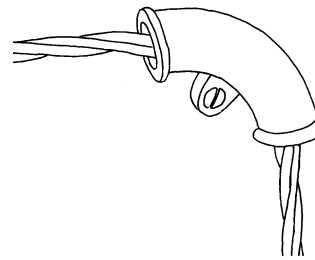

Fig. F

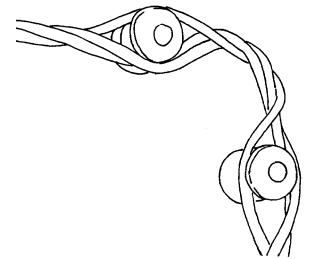
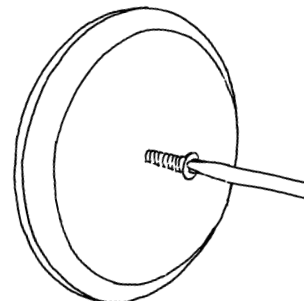





Fig. G

- 8 Per l'installazione di prese, interruttori, scatole di derivazione, spot, basi per applique a 45°, plafoniere e rosoni per decentramento consigliamo di interporre tra la parete e l'accessorio la rosetta in legno di nostra produzione fig. H
- 8 Place our original wood washers between the wall and the accessory to install any sockets, switches, connector boxes, spotlights, bases for wall lights at 45°, ceiling lights and ceiling roses, fig. H



- 9 Procedere ora al collegamento elettrico come da istruzioni di montaggio.
- 9 The electric wiring can now be completed as explained in the assembly instructions.





LAMPADINE BULBS

ARTICOLO ITEM	LAMPADA BULB	TIPO TYPE	ATTACCO SOCKET	POTENZA POWER
	Alogena LED / LED Halogen	Bulbo standard / Standard bulb	E27	70W
	Alogena LED / LED Halogen	PAR 20	E27	50W
	Alogena LED / LED Halogen	PAR 16	GU10	50W

LEGENDA

Tutti gli apparecchi di illuminazione vengono forniti senza lampade. Il “peso in gr.” degli articoli si intende “lordo”.
Le dimensioni sono espresse in mm.

All lamps are supplied without bulbs. The weight means “gross weight”. Dimensions are in millimeters.

IP	Grado di protezione contro la penetrazione di corpi solidi e acqua. Degree of protection against penetration of solid bodies and water.
IP20	Protezione contro l'ingresso di corpi solidi di \varnothing 12 mm. Nessuna protezione contro la pioggia. Protection against entry of solid bodies of \varnothing 12 mm. No protection against rain.
CE	Marcatura richiesta dalle direttive europee 93/68 e 89/336. Marking required by european directives 93/68 and 89/336.
	Apparecchio in classe I di isolamento. Appliance class I insulation.
	Apparecchio in classe II di isolamento. Appliance class II insulation.
	Apparecchio in classe III di isolamento. Appliance class III insulation.
	Apparecchio e lampada che non richiede schermo di protezione. Appliance and lamp not requiring protection screen.
	<p>Informazioni all'utilizzatore ai sensi dell'Art 13 del Dlgs 151/05 - Attuazione delle Direttive Europee 2002/95/CE, 2002/96/CE e 2003/108/CE - (Rifiuti di apparecchiature elettriche ed elettroniche - RAEE). Il simbolo del cassonetto barrato a fianco riportato indica che questa apparecchiatura deve essere oggetto di raccolta separata. È fatto quindi obbligo di non smaltire questo prodotto giunto a fine vita come rifiuto urbano.</p> <p>Lo smaltimento deve essere effettuato presso gli appositi sistemi di raccolta dei rifiuti di questo tipo, oppure mediante riconsegna al distributore all'atto di acquisto di un analogo prodotto nuovo.</p> <p>Assicurandosi che questo prodotto sia smaltito correttamente, ed evitandone usi impropri, si contribuisce ad impedire possibili conseguenze negative all'ambiente e alla salute delle persone, data la presenza al loro interno di sostanze potenzialmente pericolose.</p> <p>Lo smaltimento deve avvenire in accordo con la normativa vigente per lo smaltimento dei rifiuti, pena le sanzioni previste in caso di smaltimento abusivo di detti rifiuti (RAEE).</p> <p>Lo smaltimento abusivo del prodotto da parte dell'utente comporta l'applicazione delle sanzioni amministrative di cui all'articolo 50 e seguenti del D.Lgs. N. 22/1997 Come modificato dal D.Lgs. 3-4-2006 N. 152 successive modifiche e integrazioni.</p> <p>Information for users in accordance with European Directives 2002/95/CE and 2003/108/CE on the restriction of the use of dangerous substances in electric and electronic equipment as well as their waste disposal. The burred symbol of the rubbish bin shown on the equipment indicates that, at the end of its useful life, the product must be collected separately from the other waste.</p> <p>Therefore, any products that have reached the end of their useful life must be given to waste disposal centres specialising in separate collection of waste electrical and electronic equipment, or given back to the retailer at the time of purchasing new similar equipment, one a one for one basis.</p> <p>The adequate separate collection for the subsequent start-up of the equipment sent to be recycled, treated and disposal of in an environmentally, compatible way contributes to preventing possible negative effects on the environment and health and optimises the recycling and reuse of components making up the apparatus.</p> <p>Abusive disposal of the product by the user involves application of the administrative sanctions according to the laws in force.</p>

INDICE INDEX

ARTICOLO ITEM	PAGINA PAGE	ARTICOLO ITEM	PAGINA PAGE	ARTICOLO ITEM	PAGINA PAGE	ARTICOLO ITEM	PAGINA PAGE	ARTICOLO ITEM	PAGINA PAGE
75	16	LAR.02	126	LAR.187/DIMMER	95	RO11	118	SIB3/BL/...	85
76	19	LAR.05	126	LAR.188	95	RO12	118	SIB3/NL	85
76/FRA	19	LAR.10	100	LAR.188/INTE	95	RO13	119	SIB4/BL	85
76/SCHUKO	19	LAR.12	101	LAR.188/TEL	96	RO14	119	SIB4/BL	85
77	19	LAR.13	101	LAR.188/TV/SAT	96	RO15	119	SIB4/NL	85
77/FRA	20	LAR.15	101	LAR.189	96	SC/ROSONE	50	SIB90/BL	85
77/SCHUKO	20	LAR.15/TEL	101	LAR.190	98	SC/SUPPORTO	50	SIB90/BL/...	85
78	20	LAR.15/TV/SAT	101	LAR.191	99	SC101	26	SIB90/NL	85
79	20	LAR.20	102	LAR.191/TEL	99	SC102/FRA	26	SPR/1	50
80	17	LAR.22	103	LAR.191/TV/SAT	99	SC102/S	26	SPR/180	50
90	17	LAR.23	103	LAR.192	99	SC103	27	SPR/3	50
96	21	LAR.25	103	LAR.DER	121	SC104	27	SPR/4	50
96/FRA	21	LAR.25/TEL	103	LAR.ID1	114	SC105	27	SPR/90	50
96/SCHUKO	21	LAR.25/TV/SAT	103	LAR.ID1/DIMMER	114	SD 100	17	SPR/BOX	50
97	22	LAR.30	104	LAR.ID2	114	SD 100/IP44	17	SQ/NS/...	59
97/FRA	22	LAR.32	105	LAR.ID9	108	SD100/FRA	25	SQ/O/...	59
97/SCHUKO	22	LAR.33	105	LAR.ID9/DIMMER	109	SD100/SCHUKO	25	SQ1/NS/...	59
98	23	LAR.35	105	LAR.INT.01	120	SGA/CR/...	79	SQ1/O/...	59
98/FRA	23	LAR.35/TEL	105	LAR.INT.03	121	SGA/O/...	50	SQ180/NS/...	59
98/SCHUKO	23	LAR.35/TV/SAT	105	LAR.P1	114	SGA1/CR/...	79	SQ180/O/...	59
99	24	LAR.55/FRANCIA	111	LAR.P1/FRANCIA	115	SGA1/O/...	79	SQ3/NS/...	59
99/FRA	24	LAR.55/SCHUKO	111	LAR.P1/INTE	115	SGA180/CR/...	79	SQ3/O/...	59
99/SCHUKO	24	LAR.116	125	LAR.P1/SCHUKO	115	SGA180/O/...	79	SQ4/NS/...	59
11.416/P22/PAR20/SC	51	LAR.120	125	LAR.P1/TEL	115	SGA3/CR/...	79	SQ4/O/...	59
11.416/P22/SC	51	LAR.126	125	LAR.P1/TV/SAT	115	SGA3/O/...	79	SQ90/NS/...	59
11.416/P26/PAR20/SC	51	LAR.130	124	LAR.P13	110	SGA4/CR/...	79	SQ90/O/...	59
11.416/P26/SC	51	LAR.131/CONF.	124	LAR.P13/FRANCIA	110	SGA4/O/...	79	SQDER4/NS	59
11.416/P29/PAR20/SC	51	LAR.131/ISO	124	LAR.P13/SCHUKO	110	SGA90/CR/...	79	SQDER4/O	59
11.416/P29/SC	51	LAR.132	124	LAR.P13/TEL	110	SGA90/O/...	79	SQDER90/NS	59
11.416/PAR20/SC	51	LAR.133	123	LAR.P13/TV/SAT	110	SGATUBO8/A/CR	79	SQDER90/O	59
11.422/PAR20/SC	51	LAR.134	126	LAR.PRE.01	121	SGB/CR/...	81	SR/NS/...	67
11.516/P22/PAR20/SC	51	LAR.138.01/CONF.	123	LAR.PRE.03	121	SGB/O/...	81	SR/O/...	67
11.516/P22/SC	51	LAR.138.01/MT.	123	LIN.1	30	SGB1/CR/...	81	SR1/NS/...	67
11.516/P26/PAR20/SC	51	LAR.138.02/CONF.	123	LIN.2	30	SGB1/O/...	81	SR1/O/...	67
11.516/P26/SC	51	LAR.138.02/MT.	123	LIN.3	30	SGB105/CR/...	81	SR105/NS/...	67
11.516/P29/PAR20/SC	51	LAR.138.03/CONF.	123	LIN2/NS/26	59	SGB105/O/...	81	SR105/O/...	67
11.516/P29/SC	51	LAR.138.03/MT.	123	LIN2/O/26	59	SGB180/CR/...	81	SR180/NS/...	67
11.516/PAR20/SC	51	LAR.138.04/CONF.	123	OND1	116	SGB180/O/...	81	SR180/O/...	67
11.522/PAR20/SC	51	LAR.138.04/MT.	123	OND2	116	SGB3DX/CR/...	81	SR3/NS/...	67
1PM.S	127	LAR.138.05/CONF.	123	OND3	116	SGB3DX/O/...	81	SR3/O/...	67
1PM1	128	LAR.138.05/MT.	123	OND7	116	SGB3SX/CR/...	81	SR4/NS/...	67
1PM2	128	LAR.138.06/CONF.	123	OND8	116	SGB3SX/O/...	81	SR4/O/...	67
1PM3	128	LAR.138.06/MT.	123	OND9	116	SGB4/CR/...	81	SR75/NS/...	67
1PM4	128	LAR.138.07/CONF.	123	OND10	116	SGB4/O/...	81	SR75/O/...	67
1PM5	129	LAR.138.07/MT.	123	OND11	116	SGB75/CR/...	81	SUP.1	29
1PMIDEA	127	LAR.138.08/CONF.	123	OND12	116	SGB75/O/...	81	SUP.2	29
1PMPLANA	127	LAR.138.08/MT.	123	OND13	117	SGTUBO8/A/O	79	SUP.3	29
1PMTT	127	LAR.138.09/CONF.	123	OND14	117	SGTUBO8/DA/CR	79	TAP.10	30
2PM1	130	LAR.138.09/MT.	123	OND15	117	SGTUBO8/DA/O	79	TAP.16	30
2PM2	130	LAR.138.10/CONF.	123	RAC.1	28	SGTUBO8/L/CR	79	TAP.20	30
2PM3	130	LAR.138.10/MT.	123	RAC.2	28	SGTUBO8/L/O	79	VOL.1	29
3PM1	131	LAR.138.11/CONF.	123	RAC.3	28	SIB/BL	85	VOL.2	29
3PM2	131	LAR.138.11/MT.	123	RID.1	30	SIB/BL/...	85	VOL.3	29
3PM3	131	LAR.138.12/CONF.	123	RID.2	30	SIB/NL	85		
50/40	18	LAR.138.12/MT.	123	RO1	118	SIB1/BL	85		
CIL.10	29	LAR.140	106	RO2	118	SIB1/BL/...	85		
CIL.16	29	LAR.141	107	RO3	118	SIB1/NL	85		
CIL.20	29	LAR.141/TEL	107	RO7	118	SIB180/BL	85		
CUR.1	31	LAR.141/TV/SAT	107	RO8	118	SIB180/BL/...	85		
CUR.2	31	LAR.142	107	RO9	118	SIB180/NL	85		
CUR.3	31	LAR.187	95	RO10	118	SIB3/BL	85		

Aldo Bernardi S.r.l.
Via Vittorio Veneto 2/A
31017 Paderno del Grappa
Treviso, Italia

T +39 0423.538783
F +39 0423.539082

info@aldobernardi.it
www.aldobernardi.it



Copyright © 2015 Aldo Bernardi S.r.l.

Aldo Bernardi S.r.l. si riserva il diritto di effettuare modifiche ai prodotti senza l'obbligo di preavviso. Tutti i diritti sono riservati. I decori e tutti gli oggetti rappresentati nel catalogo possono produrre colori e tonalità non perfettamente fedeli agli originali. Il rame e l'ottone possono avere tonalità diverse da quelle raffigurate nelle foto del catalogo. Il rame e l'ottone non sono verniciati ma sottoposti ad un processo di anticatura. Ciò è dovuto alla lavorazione manuale del procedimento di anticatura. L'anticatura del rame e dell'ottone, effettuata artigianalmente, accelera ma non sostituisce l'ossidazione naturale di questi materiali che, esposti all'esterno, subiranno l'azione degli agenti specifici presenti nell'aria, diversi da zona a zona.

Aldo Bernardi S.r.l. reserves the right to modify products, without notice, anytime. All rights reserved. Decorations and all the objects represented in the catalogue can reproduce colours and shades not perfectly true to the original. Copper, brass and casting can take on different shades to those given in the catalogue. Copper and brass are not painted they are submitted to an aging process. The aging, manufacturing process, speeds up, but does not replace the natural oxidation of these materials. Copper and brass natural aging process, positioned in different environment, will be subjected to the influence of different atmospheric agents, depending from the environment.

AD
INTOTHEDESIGN.IT

Photo
INTOTHEDESIGN
Quasar
M. Gaddo
Mario Reggiani

Print
Asolana Group

Si ringrazia per la collaborazione / Thanks for collaboration
Studio progettazione interno



Aldo Bernardi®

aldobernardi.it